

- Opto-electronic wind speed sensor
- “Low Power” - Frequency output signal
- Range 0.5 ... 50 m/s
- Resolution < 0.1 m/s



Measurement principle

The cup star is set into rotation by the wind. An opto-electronic speed scanning produces a frequency, which is, proportional to the wind speed, available as output signal. The anemometer is equipped with an electronically regulated heating system in order to prevent ice from the bearings.

Mounting

When using fastening adaptors, remember that turbulences could possibly influence the characteristic curve. You should use a tube with a length of 350 mm, an outer diameter of 35 mm and a wall thickness of 5 mm. Cut an inner thread (PG 21) in the upper end of the tube (min. 13 mm). For mounting leave one hexagonal nut (SW36) at the anemometer and pass the cable through the tube. The thread of the anemometer has to be screwed into the tube until there is still enough free space to fix it with the nut.

When mounting the sensor, never turn the sensor at the aluminium tube because this can be opened. To fix and to loosen the lock nut, the sensor must be hold with a screw spanner (SW 22) above the thread!

The anemometer should be mounted principally at the top of a mast to be free in all directions. Only a lightning protection rod mounted below must overtop the sensor. If an anemometer has to be mounted on a traverse, the length must be at least 7 times the length of the mast diameter.

Dimensional Drawing

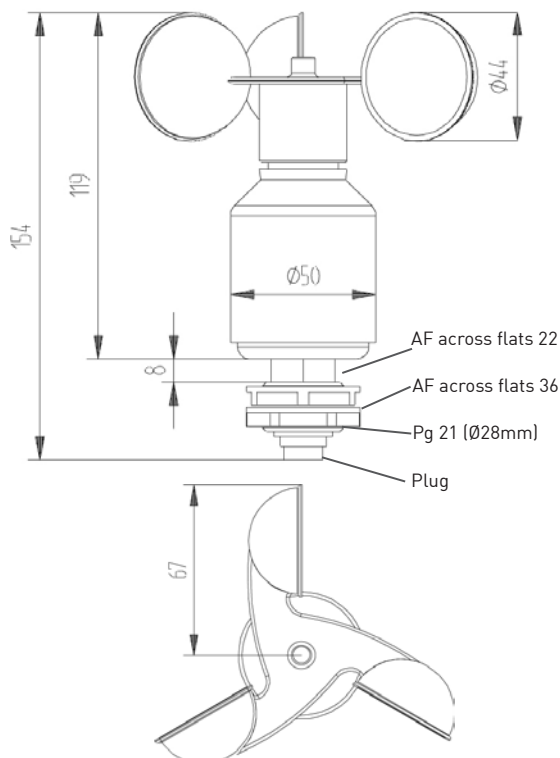

Maintenance

The anemometer requires only low maintenance thanks to its low-inertia and ball-bearing cup star. Dust or dirt may clog the space between the rotating parts and the shaft. Check the plausibility of the measurement results at regular terms and clean the device, if necessary.

In true long-term operation (years) the bearings may be subject to wear and tear showing delayed start-up behaviour or even stand-still of the anemometer. Should such a defect occur, return the instrument for repair.

Calibration

Frequency output is determined by a linear function of the wind speed:

$$\text{wind speed [m/s]} = \text{slope [m]} \times f \text{ [Hz]} + \text{offset [m/s]}$$

For measurement campaigns with extremely crucial requirements an individual calibration of each anemometer in a wind tunnel test may be worthwhile to achieve optimum accuracy and precision.

Characteristic	Description / Value
Measurement principle	Opto-electronic (slotted disc)
Accuracy	
Accuracy	± 3 % of meas. value, however ≥ 0.5 m/s
Resolution	< 0.1 m/s
Starting velocity	0.5 m/s
Operating range	
Measurement range	0 ... 50 m/s
Survival wind speed	max. 80 m/s (30 min)
Ambient temperature	-40 ... +70 °C
Electrical data	
Electrical supply	9 ... 30V DC
Electrical supply for heating	24V AC/DC @ 20W
General	
Connection	7-pole plug-connection
Mounting	For ex. onto mast tube with receptable thread Pg21 or boring Ø 29mm
Dimensions	155 x Ø 134 mm (see also dimensional drawing)
Weight	approx. 0.7 kg
Material	Housing: Aluminium Cup star: Synthetic with fibre glass
Type of ball bearings	Metallic ball bearings
Protection	IP 55
Manufacturer	Thies

Sensor connection to Ammonit Meteo-40 data logger

Sensor	Plug Pin No.	Ammonit Cable Wire Colour	Meteo-40 Counter	Supply Sensor
Wind speed Pulse output	3	white	CNT	
Supply	1	red		9 ... 36 V*
Ground	2	black		Main Ground
Heating	4	orange, orange		24 VAC/DC
	5	violet, violet		

* Supply voltage for usage with Meteo-40 data loggers.

Connect the shield logger-sided to Ground (GND)

Cable type without heating: LiYCY 3 x 0.25mm²

Cable type with heating wires: LiYCY 7 x 0.25mm²

Sensor connection diagram to Ammonit Meteo-40 data logger

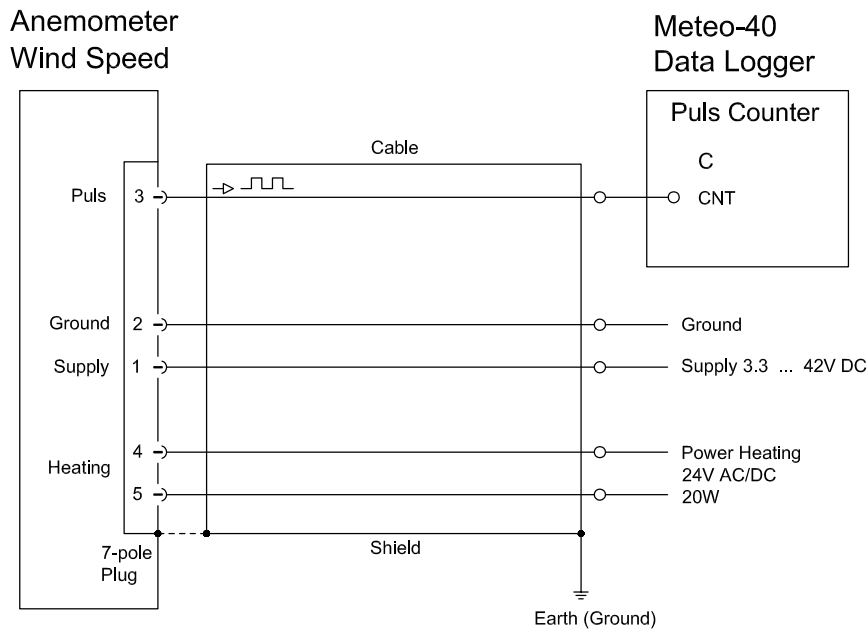

Plug and cable assembly

Coupling socket, Type: Binder, Serial 423, EMC with cable clamp

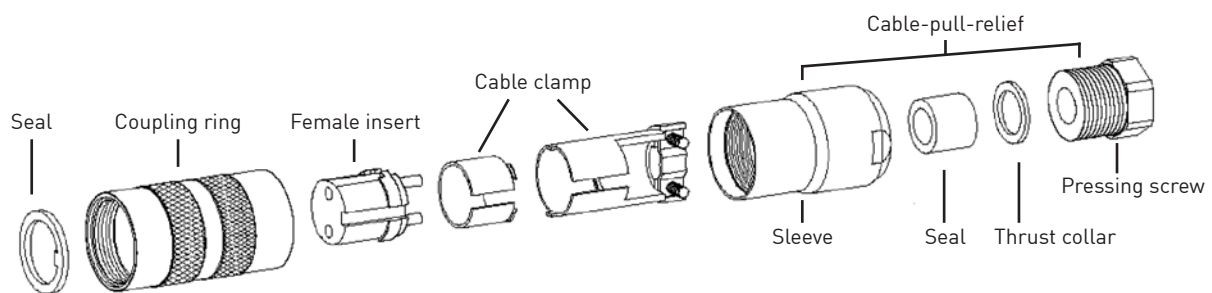

Cable connection: WITHOUT cable shield

1. Stringing parts on cable acc. to plan given above.
2. Stringing cable sheath 20 mm
3. Cutting uncovered shield 20 mm
4. Stripping wire 5 mm
5. Soldering wire to the insert.
6. Positioning outer cable sheath in cable clamp.
7. Screwing-on cable clamp.
8. Assembling remaining parts acc. to plan above.
9. Tightening pull-relief of cable by screw-wrench (SW 16 and 17).

