

Classified acc. to IEC 61400-12-1 Edition 2.0 (2017-03)

Optically-scanned cup anemometer

Thies First Class Advanced gives outstanding performance. The sensor has been classified acc. to IEC 61400-12-1 Edition 2.0. It gives optimal dynamic performance with the following characteristics:

- High accuracy
- Minimal deviation from cosine line
- Excellent behaviour to turbulences
- Minimum overspeeding
- Small distance constant
- Low start up value
- Low power consumption
- Digital output

The sensor is designed for measuring the horizontal wind velocity in the field of meteorology, climate research, site assessment, and the measurement of capacity characteristics of wind power systems (power curves). The patented design is the result of long testing in the wind tunnel. The sensor features dynamic behaviour also at high turbulence intensity, minimal overspeeding, and a low starting values. It requires only low maintenance thanks to its low-inertia and ball-bearing cup star. The anemometer is equipped with electronically regulated heating to guarantee smooth running of the ball bearings and prevent icing of shaft and slot during winter operation.



Calibration

Wind speed is determined by the linear function of the frequency output f:

$$\text{wind speed [m/s]} = \text{slope [m]} \times f \text{ [Hz]} + \text{offset [m/s]} \quad (\text{Manufacturer instructions: Slope} = 0.0462 \text{ m, Offset} = 0.21 \text{ m/s})$$

For wind resource assessment, anemometers have to be calibrated acc. to MEASNET. We recommend calibrating anemometers in the wind tunnel of Ammonit Wind Tunnel GmbH (ammonit-windtunnel.com).

Classification acc. to IEC 61400-12-1 Edition 2.0 (2017-03)

The driving and braking forces used in the numerical model have been derived from the measured step response of the tested anemometer according to IEC 61400-12-1 Edition 2.0. The direct influence of air density was measured using a specially designed variable air density wind tunnel, instead of calculating the influence of air density by using torque measurements.

	Class A	Class B	Class C	Class D
Heating ON	1.8	2.0	1.8	2.0
Heating OFF	2.3	2.7	4.4	4.6

Source: Summary report AK 151023-1.2 Cup Anemometer Classification, Deutsche WindGuard Tunnel Services GmbH, Varel, Germany, 2017.

Operational standard uncertainty acc. to IEC 1400-12-1

The operational standard uncertainty describes the maximum deviation of the wind speed measured by the anemometer compared with the real wind speed. The table indicates the operational standard uncertainty at 10 m/s:

	Class A	Class B	Class C	Class D
Heating ON	0.10 m/s	0.12 m/s	0.10 m/s	0.12 m/s
Heating OFF	0.13 m/s	0.16 m/s	0.25 m/s	0.27 m/s

Linearity (MEASNET)

The MEASNET required linearity for anemometers is $r > 0.99995$. The Thies First Class Advanced II offers $r > 0.99999$ (4 ... 20 m/s).

Dimensional drawing

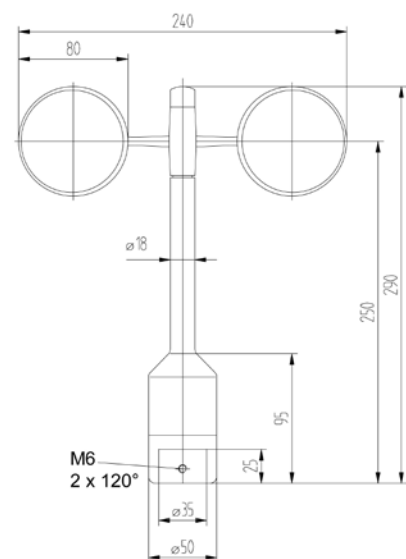

Specification

Characteristics	
Physical functionality	Optically-scanned cup anemometer
Delivered signal	Frequency output (pulse)
Accuracy	
Accuracy	0.3 ... 50 m/s 1% of meas. value or < 0.2 m/s
Linearity	Correlation factor r between frequency f and wind speed y $y = 0.0462 \times f + 0.21$ typical $r > 0.999\ 99$ (4 ... 20 m/s)
Starting velocity	< 0.3 m/s
Resolution	0.05 m wind run
Distance constant	< 3 m (acc. to ASTM D 5096 - 96) 3 m acc. to ISO 17713-1
Turbulent flow	Deviation Δv turbulent compared with stationary horizontal flow $-0.5\ \% < \Delta v < +2\ \%$ Frequency < 2 Hz
Inclined flow - mean deviation from cosinus line - Turbulence effect	< 0.1 % (in range of $\pm 20^\circ$) < 1 % (in the range up to 30% turbulence intensity)
Wind load	Approx. 100 N @ 75 m/s
Operating range	
Measuring range	0.3 ... 75 m/s
Survival speed	80 m/s (mind. 30 min)
Permissible ambient conditions	-50 ... +80 °C, all occurring situations of relative humidity
Electrical data	
Output signal	Form rectangle, 1082 Hz @ 50 m/s, supply voltage max. 15 V
Electrical supply for optoelec. scanning	Voltage: 3.3 ... 48 VDC (galvanic isolation from housing) Current: 0.3 mA @ 3.3 V (w/o external load) < 0.5 mA @ 5 V (w/o external load)
Electrical supply for heating*	Voltage: 24 V AC/DC (galvanic isolation from housing) Idling voltage: max. 30 V AC, max. 48 VDC Power consumption: 25 W
General	
Connection	8-pole plug-connection for shielded cable in the shaft
Mounting	on mast tube R1"
Dimensions	290 x 240 mm
Fixing boring	35 x 25 mm
Weight	approx. 0.5 kg
Material	Housing: Anodised aluminium Cup star: Carbon-fibre-reinforced plastic
Type of bearings	Metallic ball bearings
Protection	IP 55 (DIN 40050)
Patent	EP 1 398 637 DE 103 27 632 EP 1 489 427
EMC	EN 61000-6-2:2001 (immunity) EN 55022:2001, Class B (interfering transmission)
Manufacturer	Thies

Sensor connection to Ammonit Meteo-40 data logger

Sensor	Plug Pin No.	Ammonit Cable Wire Colour	Meteo-40 Counter	Supply Sensor
Wind speed Pulse output	1	white	CNT	
Supply	3	red		9 ... 36 V*
Ground	2	black		Main Ground
Heating	7	orange, orange		24 VAC/DC
	8	violet, violet		

* Supply voltage for usage with Meteo-40 data loggers.

Cable type without heating: LiYCY 3 x 0.25 mm²

Cable type with heating wires: LiYCY 7 x 0.25 mm²

Sensor connection diagram to Ammonit Meteo-40 data logger

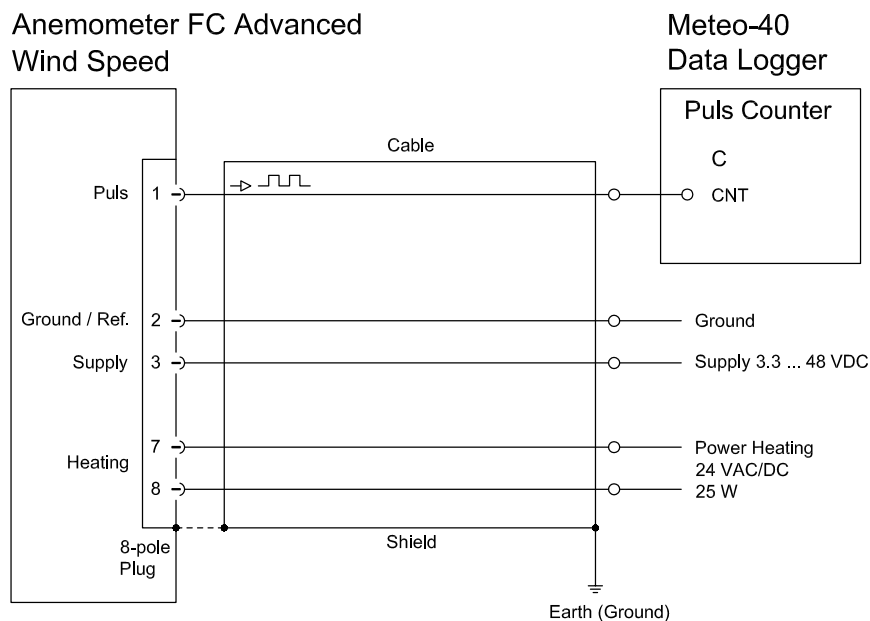

Connection recommendations for the cable shield

Sensor carrier	Sensor	Shielding / Ground
Metallic met mast, grounded	Non-isolated mounting on the met mast (e.g. by using metallic brackets, holders, etc.)	Connect cable shield only at the side of the data logger to ground.
Metallic met mast, grounded	Isolated mounting at the met mast (e.g. by using non-metallic brackets, holder etc. or metallic brackets, holders etc. with isolated plastic adapters)	Connect cable shield at sensor plug and at the side of the data logger to ground.
Metallic met mast, non-grounded	Non-isolated mounting on the met mast (e.g. by using metallic brackets, holders etc.)	Connect cable shield at sensor plug and at the side of the data logger to ground.

Plug and cable assembly

Coupling socket, Type: Binder, Serial 423, EMC with cable clamp

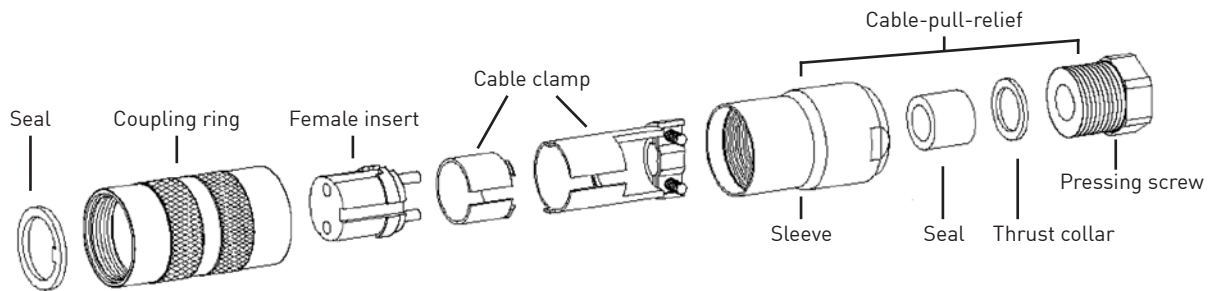

Cable connection: WITH cable shield

1. Stringing parts on cable acc. to plan given above.
2. Stripping cable sheath 20 mm
Cutting uncovered shield 15 mm
Stripping wire 5 mm

A) Putting shrink hose or insulation tape between wire and shield

B) If cable diameter permits, put the shield backward on the cable sheath.

3. Soldering wire to the insert, positioning shield in cable clamp.
4. Screwing-on cable clamp.
5. Assembling remaining parts acc. to plan above.
6. Tightening pull-relief of cable by screw-wrench (SW16 and 17).

A)

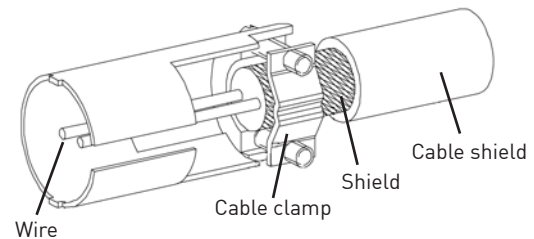

B)

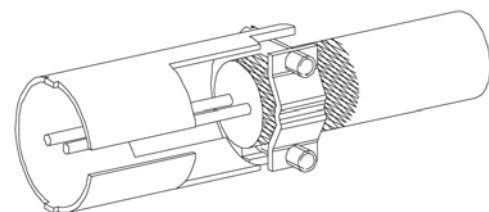

Cable connection: WITHOUT cable shield

1. Stringing parts on cable acc. to plan given above.
2. Stringing cable sheath 20 mm
3. Cutting uncovered shield 20 mm
4. Stripping wire 5 mm
5. Soldering wire to the insert.
6. Positioning shield in cable clamp.
7. Screwing-on cable clamp.
8. Assembling remaining parts acc. to plan above.
9. Tightening pull-relief of cable by screw-wrench (SW 16 and 17).

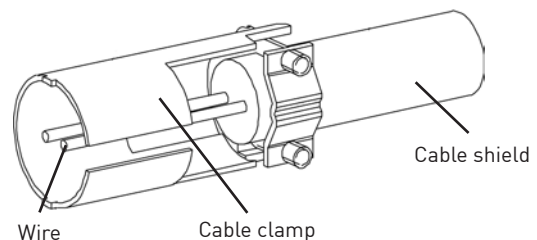

Abstract: Summary of cup anemometer classification

Acc. to IEC 61400-12-1 Edition 2.0 [2017-03] Classification Scheme

Reference:

Deutsche WindGuard Wind Tunnel Services GmbH AK 151023-1.2
 Measuring period: 04.2014 - 05.2017
 Test site: Varel, Germany
 Wind Tunnel: Deutsche WindGuard Wind Tunnel Services GmbH, Varel

Tilt Angular Response

According to:

- IEC 61400-12-1 Edition 2.0
Wind Turbine Power Performance Testing 2017-03
- WindGuard Quality System Procedure for Calibration of Wind Speed Sensors at non-horizontal inflow conditions: D 5832

Result:

Figure showing the of axis response of Thies First Class Advanced anemometer for wind tunnel speeds of 4 m/s, 8 m/s, 12 m/s and 16 m/s.

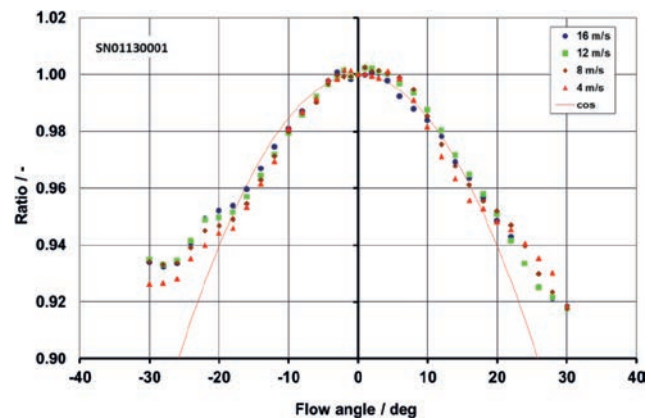

Class A Classification

According to:

- IEC 61400-12-1 Edition 2.0
Wind Turbine Power Performance Testing 2017-03

Influence parameter range:

Wind speed range: $V = 4 \dots 16 \text{ m/s}$
Turbulence intensity range: $0.03 - 0.12 + 0.48/V$
Turbulence structure: $1.0/0.8/0.5$
Air temperature: $0 \dots +40 \text{ }^\circ\text{C}$
Air density: $0.9 \dots 1.35 \text{ kg/m}^3$
Flow angle: $-3^\circ \dots 3^\circ$
Wind simulation: Kaimal wind spectrum with longitudinal turbulence length scale of 350m

Result:

Classification Index: **A 1.8** (Internal shaft heating: ON)
 Classification Index: **A 2.3** (Internal shaft heating: OFF)

Source: Summary of Cup Anemometer Classification, Adolf Thies GmbH & Co.KG, Deutsche WindGuard Tunnel Services GmbH, Varel, 2017.

FCA II - SN 01130001 - heating on

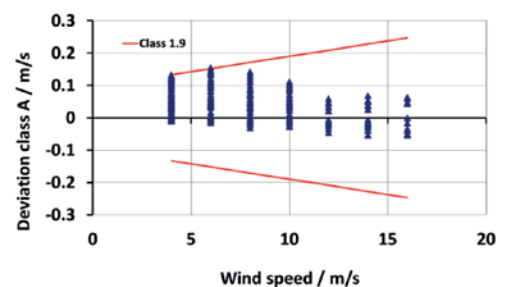

FCA II - SN 01130001 - heating off

