

- New and improved version of First Class wind vane
- High level of measuring accuracy (0.5°) and resolution (0.35°)
- Output: 10-bit serial-synchronous (compatible with Ammonit Meteo-40 data loggers)
- Measurement range 0 ... 360°
- Low current consumption (3.3V @ 1.4 mA)

Description

The wind vane serves for the detection of the horizontal wind direction in the field of meteorology and environmental protection. The axis of the wind vane is running in ball bearings and carries a diametrically magnetized magnet at the inner end. The angle position of the axis is scanned contact-free by a magnetic angle sensor (TMR-Sensor, Tunnel Magneto Resistance) through the position of the magnet field. As the sensor is operated the magnetic saturation, effects by external magnetic fields can almost be eliminated. The connected electronics calculated the angle position of the axis and provides the respective serial-synchronous output signal.

Benefits of Thies TMR wind vanes

Thies TMR wind vanes have a clear advantage towards potentiometer wind vanes in terms of accuracy and reliability.

Wind vane	Accuracy
Thies First Class TMR	± 0.75°
Thies First Class Potentiometer	± 1°



Dimensional drawing

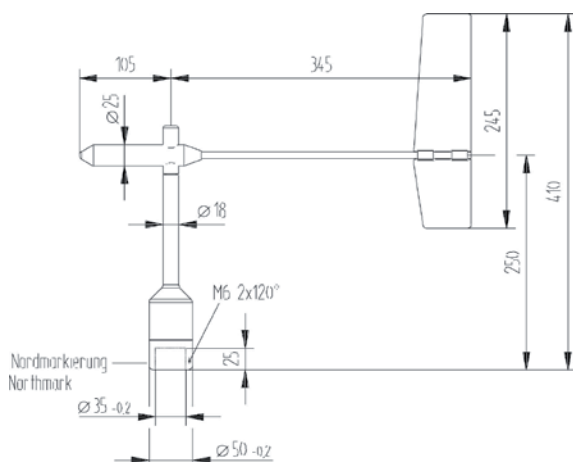

Additionally TMR wind vanes do not have a north gap and thanks to their solid state design they are subject to less mechanical wear than potentiometer wind vanes. TMR wind vanes do not have moving parts, except the bearings.

Mounting

Mount the wind vane onto a pipe socket of 1" (Ø 33.4 mm) and a length of at least 25 mm. The pipe socket must have an inner diameter of at least 25 mm depending on the plug. The wind vane is connected electrically with a plug. Set the sensor onto the pipe socket, and fix it on the mast or tube (2x M6 Allen head screws, female hexagon).

To avoid damage due to lightning, a protection rod, adapters of POM for isolated mounting and proper grounding of all metal parts is recommended.

Refer to the next page for connection recommendations for the cable shield.

Specifications

Characteristic	Description / Value
Measurement principle	Magnetic
Measurement range	0 ... 360°
Accuracy	± 0.75°
Resolution	0.35°
Survival speed	max. 85 m/s, 30 min
Starting threshold	< 0.5 m/s at 10° amplitude (acc. to ASTM D 5366-96) < 0.2 m/s at 90° amplitude (acc. to VDI 3786 Part 2)
Delay distance	< 1.8 m (acc. to ASTM D 5366-96)
Damping ratio	D > 0.3 (acc. to ASTM D 5366-96)
Quality factor	K > 1
Output	10-bit serial-synchronous (compatible with Ammonit Meteo-40 data loggers)
Operating voltage	3.3 ... 42 VDC
Operating voltage heating	24 V DC/AC, 45 ... 65 Hz (galvanically isolated from housing), max. 25 W
Ambient temperature	-50 ... +80 °C
Connection	8-pole plug connection for shielded cable in the shaft
Mounting	Mounting on mast 1" (DIN EN 10255; 1" = Ø 33.4 mm) 1 ½" with separate adapter (optional)
Material	Aluminum
Type of ball bearings	Metallic ball bearings
Weight	approx. 0.7 kg
Protection	IP 55
Manufacturer	Thies

Wind vane assembly

Before the sensor can be installed at its selected site, it has to be assembled.

Tools are not required!

1. Remove the wind vane housing from the packaging
2. Remove cap by counter-clockwise rotation.
3. Remove wind vane from packaging.
4. Assemble the wind vane on the housing as shown in the picture.
5. Wind vane rotate until it falls into the guide.
6. Put the cap on the thread, and tighten it manually by strong clockwise rotation.
Do not use tools!

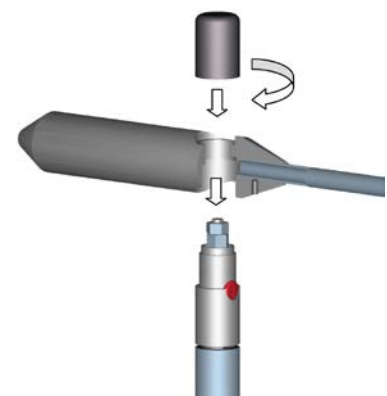
Remark

The wiring has to be prepared in a way that plug and cable will be pushed through the instrument carrier, mast, traverse etc. and can be connected to the sensor at mechanical mounting.

Connection recommendations for the cable shield

Sensor carrier	Sensor	Shielding / Ground
Metallic met mast, grounded	Non-isolated mounting on the met mast (e.g. by using metallic brackets, holders, etc.)	Connect cable shield only at the side of the data logger to ground.
Metallic met mast, grounded	Isolated mounting at the met mast (e.g. by using non-metallic brackets, holder etc. or metallic brackets, holders etc. with isolated plastic adapters)	Connect cable shield at sensor plug and at the side of the data logger to ground.
Metallic met mast, non-grounded (not recommended by Ammonit)	Non-isolated mounting on the met mast (e.g. by using metallic brackets, holders etc.)	

Sensor connection to Ammonit Meteo-40 data logger

Sensor	Plug Pin No.	Ammonit Cable Wire Colour	Meteo-40 Digital	Supply Sensor
Wind Direction Data	5	white	IN	
Clock	4	blue	CLK	
Supply	3	red		9 ... 36 V*
Ground	2	black		Main Ground
Heating	7	orange, orange		24 V AC/DC
	8	violet, violet		

* Supply voltage for usage with Meteo-40 data loggers.

Cable type without heating: LiYCY 4 x 0.25 mm²

Cable type with heating wires: LiYCY 8 x 0.25 mm²

Sensor connection diagram to Ammonit Meteo-40 data logger

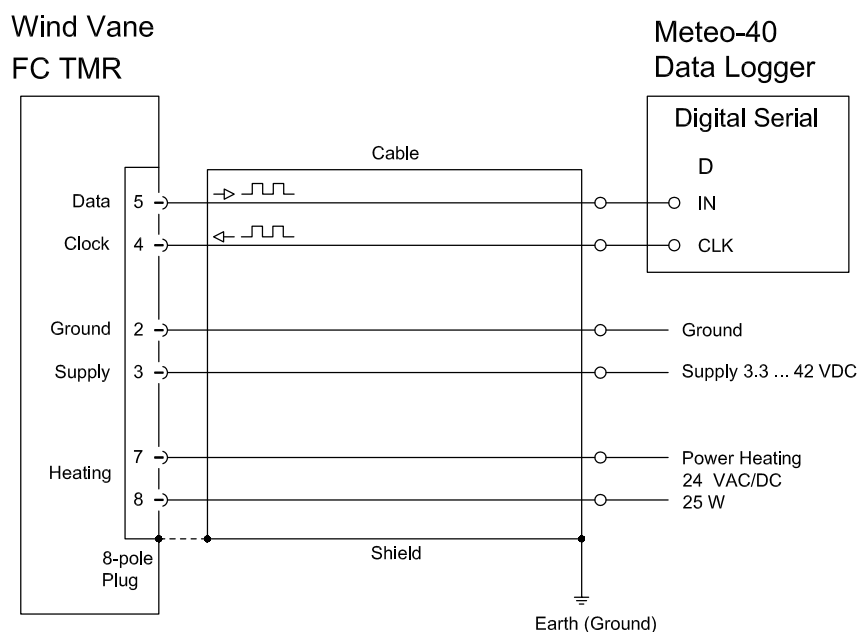

Plug and cable assembly

Coupling socket, Type: Binder, Serial 423, EMC with cable clamp

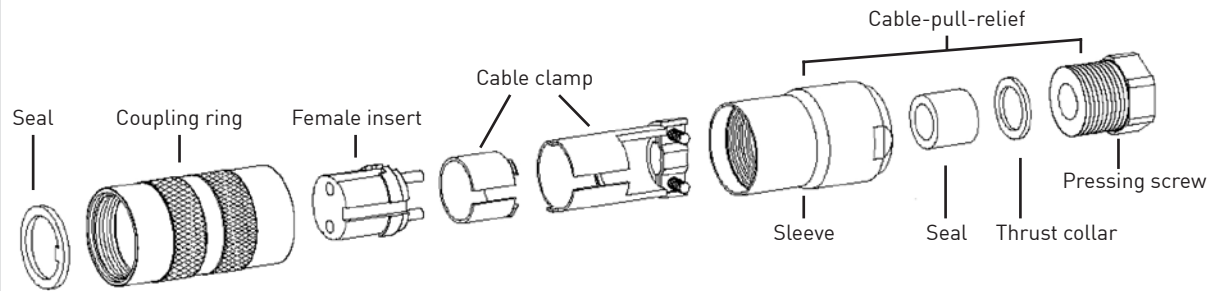

Cable connection: WITH cable shield

1. Stringing parts on cable acc. to plan given above.
2. Stripping cable sheath 20 mm
Cutting uncovered shield 15 mm
Stripping wire 5 mm

A) Putting shrink hose or insulation tape between wire and shield

B) If cable diameter permits, put the shield backward on the cable sheath.

3. Soldering wire to the insert, positioning shield in cable clamp.
4. Screwing-on cable clamp.
5. Assembling remaining parts acc. to plan above.
6. Tightening pull-relief of cable by screw-wrench (SW16 and 17).

A)

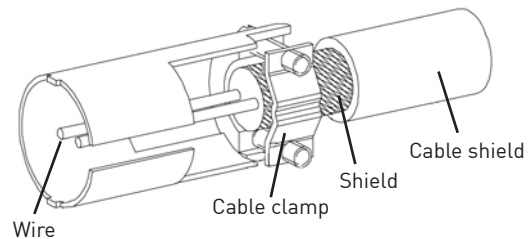

B)

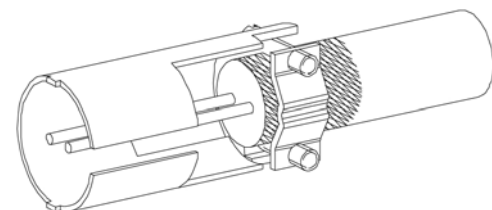

Cable connection: WITHOUT cable shield

1. Stringing parts on cable acc. to plan given above.
2. Stringing cable sheath 20 mm
3. Cutting uncovered shield 20 mm
4. Stripping wire 5 mm
5. Soldering wire to the insert.
6. Positioning shield in cable clamp.
7. Screwing-on cable clamp.
8. Assembling remaining parts acc. to plan above.
9. Tightening pull-relief of cable by screw-wrench (SW 16 and 17).

