

SATEL-LP9

900 MHz wireless transceiver (transmitter and receiver) with RS-232 and RS-485 interface, can be extended with I/O extension modules



Data sheet
3586_en_A

© SATEL

2015-12-21

1 Description

Wireless communication is based on Trusted Wireless 2.0 technology. The high demand for a interference-free data transmission using the license-free 900 MHz band, in particular via the use of the FHSS method (FHSS) and 128-bit data encryption (AES), is fulfilled.

In addition to an RS-232 and RS-485 2-wire interface, the SATEL-LP9 wireless module supports the option of directly connecting up to 32 I/O extension modules in the station structure via the DIN rail connector.

Addressing of the wireless module and I/O mapping of the I/O extension modules is carried out quickly and easily by means of the thumbwheel on the front. Programming knowledge is not required.

The SATEL-LP-CONF configuration and diagnostics software for special functionality and diagnostic options in the wireless module is available free of charge.

Features

- Flexible network applications: I/O data, serial data, PLC/Modbus RTU mode
- Adjustable data rates for the wireless interface
- Easy point-to-point or network structures (star, repeater)
- Quick and easy startup thanks to simple wireless module addressing using the thumbwheel on the front
- Integrated RS-232 and RS-485 interface
- Can be extended with up to 32 I/O modules per station via DIN rail connector (hot-swappable)
- 128-bit data encryption (AES)
- Unique network addressing via plug-in configuration memory for secure, parallel operation of multiple networks (different RF bands)
- Data rates and ranges can be adjusted



This product is only for export outside of the European Economic area.



Make sure you always use the latest documentation.
It can be downloaded from the product at www.satel.com.

2	Table of contents	
1	Description	1
2	Table of contents	2
3	Ordering data	3
4	Technical data	4
5	Safety regulations and installation notes.....	6
5.1	Installation notes	6
5.2	Installation and operation.....	6
5.3	Safety regulations for installation in potentially explosive areas	7
5.4	Conformance.....	7
6	Installation	8
6.1	Structure	8
6.2	Basic circuit diagram	8
6.3	Display and diagnostic elements	9
6.4	Assembly/removal	11
6.5	Connecting the cables	12
6.6	Serial pin assignment	12
7	Startup and configuration	14
7.1	Resetting to the default settings.....	14
7.2	Setting the station address (RAD-ID)	14
7.3	I/O data transmission	15
7.4	Serial data transmission	15
7.5	PLC/Modbus RTU mode	15
7.6	Behavior of the input and output modules in the event of an interrupted wireless connection	15
7.7	Saving the wireless network	16
7.8	Copying device settings to new network devices	16
7.9	SATEL-LP-CONF configuration and diagnostics software.....	17
8	Application example	17

3 Ordering data

Description	Type	Order No.	Pcs./Pkt.
Bidirectional, 900 MHz transceiver for wireless transmission of serial and I/O data	SATEL-LP9	YM0409	1
Accessories	Type	Order No.	Pcs./Pkt.
Digital I/O extension module with 4 digital inputs (0...250 V AC/DC), with screw connection, incl. DIN rail connector	SATEL-LP-DI4	YI0101	1
Digital I/O extension module with 4 digital relay outputs (5 A, 250 V AC/ 24 V DC), with screw connection, incl. DIN rail connector	SATEL-LP-DOR4	YI0102	1
Analog extension module with 4 analog current inputs (0/4 mA ... 20 mA), with screw connection, incl. DIN rail connector	SATEL-LP-AI4	YI0103	1
Analog I/O extension module with 4 analog current/voltage outputs (0/4 mA ... 20 mA, 0...10 V), with screw connection, incl. DIN rail connector	SATEL-LP-AO4	YI0104	1
Analog/digital I/O extension module with 2 digital inputs/outputs (0...250 V AC/DC) and 1 analog input (0/4...20 mA) and output (0/4 ... 20 mA, 0...10 V), with screw connection, incl. DIN rail connector	SATEL-LP-DAIO6	YI0105	1
Digital I/O extension module with 8 digital inputs (0 ... 30.5 V DC) or 2 pulse inputs (0 ... 100 Hz), with screw connection, including DIN rail connector	SATEL-LP-DI8	YI0106	1
Digital I/O extension module with 8 digital transistor outputs (30.5 V DC/200 mA), with screw connection, including DIN rail connector	SATEL-LP-DO8	YI0107	1
Temperature I/O extension module with 4 PT 100 inputs (-50...+250°C), with screw connection, including DIN rail connector	SATEL-LP-PT100	YI0108	1
USB data cable for communication between the PC and SATEL-LP devices. Energy supply for diagnostics and configuration via the USB port of the PC, cable length: 2 m	SATEL-LP-PROG	YC0520	1
Memory stick for saving individual configuration data for the SATEL-LP wireless module	SATEL-LP-MEMORY	YO0010	1
Randomly-generated , pre-configured SATEL-LP-CONF stick for easy and secure network addressing of a SATEL-LP wireless module	SATEL-LP-CONF1	YO0002	1
Omnidirectional antenna, IP65 protection, gain of 8 dBi, Type N (female)	SATEL-LP-ANT9N	YA1900	1
Antenna, portable, 820 - 960 MHz	SATEL-LP-ANT8/9	YA0899	1
Antenna cable, 2 m length, Type N (male) -> RSMA (male), 50 Ω impedance	SATEL-LP-RF2	YC1520	1
Feed-through cable, 0.5 m length, Type N (female) -> RSMA (male), 50 Ω impedance	SATEL-LP-RF50	YC1550	1
Low-loss cable, 50 Ω impedance, specify length, connectors required 1.34 dB/10 m @896/900 MHz 2.36 dB/10 m @ 2.4 GHz	ECOFLEX10	YC1004	1
Low-loss cable, 50 Ω impedance, specify length, connectors required 0.92 dB/10 m @896/900 MHz 1.63 dB/10 m @ 2.4 GHz	ECOFLEX15	YC1006	1
Connector, Type N (male) -> Type N (male) for ECOFLEX10 cable	CONNECTORS	YC1003	1
Connector, Type N (male) -> Type N (male) for ECOFLEX15 cable	CONNECTORS	YC1007	1
Power supply for DIN rail, 100 - 240 V AC supply, 24 V DC/2.5 A output	PS-DIN-2	YP0118	1

4 Technical data

Dimensions

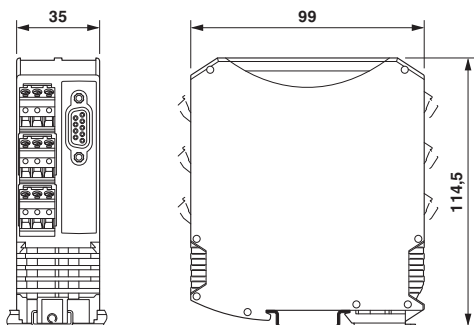

Dimensions W/H/D	35 mm / 99 mm / 114.5 mm
------------------	--------------------------

General data

Overvoltage category	II
Degree of protection	IP20
Pollution degree	2
Type of housing	PA 6.6-FR, black
Flammability rating according to UL 94	V0

Supply

Supply voltage range	10.8 V DC ... 30.5 V DC
Max. current consumption	328 mA (@24 V DC)
Transient surge protection	Yes
Nominal power consumption	1.7 W (30 dBm)
Power consumption	8.4 W (peak; 30 dBm)

Wireless interface

Antenna connection method	RSMA (female)
Direction	Bi-directional
Frequency	900 MHz
Frequency range	902 MHz ... 928 MHz
Data transmission rate (adjustable)	16 kbps 125 kbps 250 kbps 500 kbps
Receiver sensitivity	-112 dBm (16 kbps) -105 dBm (125 kbps) -102 dBm (250 kbps) -95 dBm (500 kbps)
Transmission power	max. 1 W (adjustable)
Security	128-bit data encryption

RS-232, 3-conductor

Connection method	plug-in screw terminal block D-SUB 9 (socket)
Transmission speed	0.3 ... 115.2 kbps

RS-485, 2-wire

Connection method	plug-in screw terminal block
Transmission speed	0.3 ... 115.2 kbps
Termination resistor (switchable via DIP switches)	390 Ω / 150 Ω / 390 Ω

RSSI output

Number of outputs	1
Voltage output signal	0 V ... 3 V

RF link relay output

Number of outputs	1
Contact type	PDT
Contact material	PdRu, gold-plated
Maximum switching voltage	30 V AC/DC
Max. switching current	500 mA
Electrical service life	5 x 10 ⁵ cycles with 0.5 A @ 30 V DC

Connection data

Connection method	Screw connection
Conductor cross section, solid	0.2 mm ² ... 2.5 mm ²
Conductor cross section, flexible	0.2 mm ² ... 2.5 mm ²
Conductor cross section AWG/kcmil	24 ... 14
Stripping length	7 mm
Tightening torque	0.6 Nm

Status indication

Status display	Green LED (supply voltage, PWR) Green LED (bus communication, DAT) Red LED (periphery error, ERR) 3 x green, 1 x yellow LED (LED bar graph receive quality, RSSI) Green LED (receive data, RX) Green LED (transmit data, TX)
----------------	---

Ambient conditions

Ambient temperature (operation)	-40°C ... 70°C -40°F ... 158°F
Ambient temperature (storage/transport)	-40°C ... 85°C -40°F ... 185°F
Permissible humidity (operation)	20% ... 85%
Permissible humidity (storage/transport)	20% ... 85%
Altitude	2000 m
Vibration (operation)	in accordance with IEC 60068-2-6: 5g, 10 Hz ... 150 Hz
Shock	16g, 11 ms

Certification

Conformance	FCC Directive, Part 15.247 ISC Directive RSS 210
UL, USA / Canada	Class I, Div. 2, Groups A, B, C, D
UL, USA	Class I, Zone 2, AEx nA nC IIC T4
UL, Canada	Class I, Zone 2, Ex nA nC nL IIC T4 Gc X
CSA	CSA C22.2

5 Safety regulations and installation notes

5.1 Installation notes



Please note that, in combination with antennas, the maximum permissible transmission power may be exceeded. Please set the transmission power via the software.

The use of antennas with a gain greater than 6 dBi may require that the transmit power be reduced from the default setting of 30 dBm. Regulations limit the equivalent isotropically-radiated power (EIRP) to 36 dBm. The EIRP may be calculated as the transmit power (Pt) minus any cable loss (Lc) plus the antenna gain (Ga).

$$EIRP = Pt - Lc + Ga$$

For example, in the case of a 12 dBi antenna used with a cable run with a 4 dB loss, the transmit power must be reduced to 28 dBm or less such that the EIRP does not exceed 36 dBm.



The SATEL-LP-CONF configuration and diagnostic software can be used to configure the transmit power.



Operation of the wireless system is only permitted if accessories available from SATEL are used. The use of other accessory components may invalidate the device approval status.

5.2 Installation and operation

Follow the installation instructions.



NOTE: Installation, operation, and maintenance may only be carried out by professionals.

Error-free operation of this device can only be ensured if transport, storage, and assembly are carried out correctly and operation and maintenance are carried out with care.

When installing and operating the device, the applicable safety directives (including national safety directives), accident prevention regulations, as well as general technical regulations, must be observed.



WARNING: Risk of electric shock
During operation, certain parts of this device may carry hazardous voltages. Disregarding this warning may result in damage to equipment and/or serious personal injury.



NOTE: Access to circuits within the device is not permitted.

Provide a switch/circuit breaker close to the device, which is labeled as the disconnect device for this device.

Provide overcurrent protection ($I \leq 6 \text{ A}$) in the installation.



During maintenance work, disconnect the device from all effective power sources.



NOTE: The IP20 degree of protection (IEC 60529/EN 60529) of the device is intended for a clean and dry environment. Do not subject the device to mechanical and/or thermal loads that exceed the specified limits.

The radio should not be operated without an antenna or terminating load on the antenna connector.



NOTE: Prolonged operation without an antenna or terminator may result in damage to the radio.

5.3 Safety regulations for installation in potentially explosive areas

Installation in areas with a danger of dust explosions



WARNING: Explosion hazard

The device is not designed for use in atmospheres with a danger of dust explosions.

Installation in Class I, Div. 2 or Zone 2



WARNING!

The device is designed for installation in Class I, Division 2/Zone 2 (UL/cUL) potentially explosive areas. Observe the specified conditions for use in potentially explosive areas.

Install the device into a housing (control or distributor box) with at least IP54 protection (EN 60529) and is certified for use in Class I, Div. 2 or Zone 2.

When installing and connecting the supply and signal circuits observe the requirements of EN 60079-14. Only devices suitable for operation in Ex zone 2 and the conditions at the application site may be connected to the circuits in zone 2.

In potentially explosive areas, only connect and disconnect cables when the power is disconnected.

Installation/removal of the devices on/from the DIN rail connector may only be performed when no voltage is applied.

5.4 Conformance

FCC



NOTE:

This equipment has been tested and found to comply with the limits for a Class A digital device, pursuant to part 15 of the FCC rules. These limits are designed to provide reasonable protection against harmful interference when the equipment is operated in a commercial environment. This equipment generates, uses and can radiate radio frequency energy and, if not installed and used in accordance with the instruction manual, may cause harmful interference to radio communications. Operation of this equipment in a residential area is likely to cause harmful interference, in which case, the user will be required to correct the interference at his own expense.

Changes or modifications not expressly approved by the party responsible for compliance could void the user's authority to operate the equipment.

This equipment complies with the FCC RF radiation exposure limits set forth for an uncontrolled environment. This equipment should be installed and operated with a minimum distance of 20 cm between the radiator and your body.

- FCC certificate: SGV-SHR-900

Industry Canada (IC)

Operation is subject to the following two conditions: (1) this device may not cause interference, and (2) this device must accept any interference, including interference that may cause undesired operation of the device.

To reduce potential radio interference to other users, the antenna type and its gain should be so chosen that the equivalent isotropically radiated power (EIRP) is not more than that permitted for successful communication.

This device has been designed to operate with the antennas listed in this document and having a maximum gain of 12 dB. Antennas not included in this list or having a gain greater than 12 dB are strictly prohibited for use with this device. The required antenna impedance is 50 Ω.

Under Industry Canada regulations, this radio transmitter may only operate using an antenna of a type and maximum (or lesser) gain approved for the transmitter by Industry Canada. To reduce potential radio interference to other users, the antenna type and its gain should be so chosen that the equivalent isotropically radiated power (EIRP) is not more than that necessary for successful communication.

- IC certificate: IC4720C-SHR900

6 Installation



NOTE: electrostatic discharge!

The device contains components that can be damaged or destroyed by electrostatic discharge. When handling the device, observe the necessary safety precautions against electrostatic discharge (ESD) according to EN 61340-5-1 and IEC 61340-5-1.

6.1 Structure

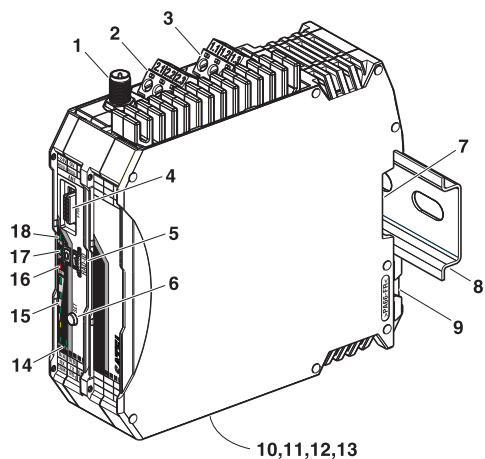

Figure 1 SATEL-LP9

Pos.	Designation
1	RSMA antenna connection (socket)
2	Test output RSSI (0...3 V DC) for evaluation of the wireless signal strength
3	Device supply (+24 V DC, 0 V)
4	12-pos. programming interface (S-PORT)
5	RAD ID address setting via thumbwheel
6	SET button
7	Connection option for DIN rail connector
8	DIN rail
9	DIN rail release latch
10	Connection terminal block RS-485 interface
11	Connection terminal block RS-232 interface
12	Relay output with PDT contact (floating)
13	D-SUB 9 connector (RS-232 interface)
14	RS-232/485 serial interface status LED (RX/TX)
15	LED bar graph for displaying the wireless signal strength
16	ERR status LED, red (communication error)
17	DAT status LED, green (BUS communication)
18	PWR status LED, green (supply voltage)

6.2 Basic circuit diagram

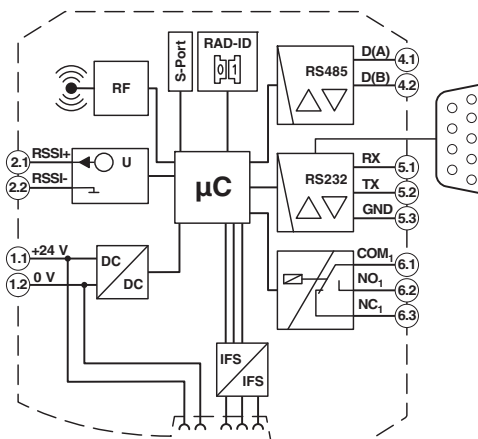

Figure 2 Circuit diagram

6.3 Display and diagnostic elements

Nine LEDs on the SATEL-LP9 indicate the operating status.

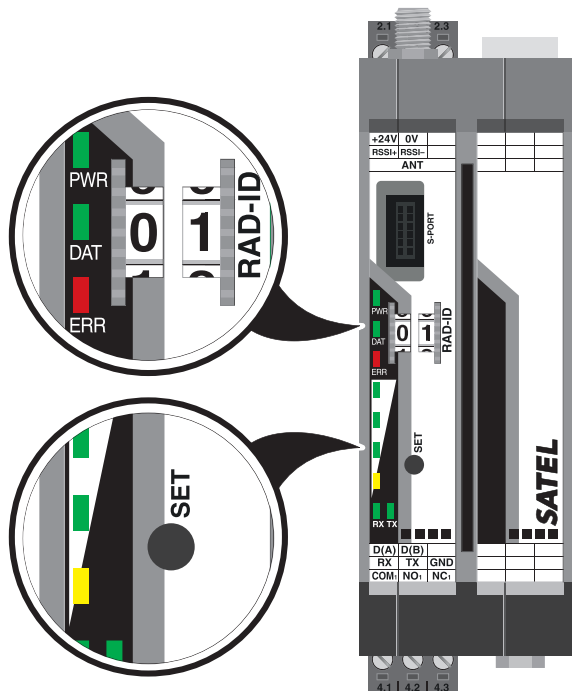

Figure 3 Display and diagnostic elements

PWR LED

The green PWR LED indicates the supply voltage status.

- Off: No supply voltage
- On: Supply voltage OK

DAT LED

The green DAT LED indicates the bus communication status.

- Off: No communication
- Flashing: Configuration mode
- On: Cyclic data communication

ERR LED

The red ERR LED indicates the error status, e.g., no corresponding output module found (e.g., incorrect addressing).

- Off: No error
- Flashing: Slow (1.4 Hz)
 - Wireless module in I/O data mode (wire in/wire out):** double assignment of the I/O MAP address, missing input module, missing output module, modified RAD ID
 - Wireless module in PLC/Modbus RTU mode:** double assignment of the I/O MAP address, modified RAD ID, no Modbus communication
 - Example: watchdog active
- Fast (2.8 Hz)
 - Example: wireless connection interrupted
- On: Local bus error
 - Example: input or output module not read

LED bar graph

The LED bar graph indicates the receive signal strength.

Bar graph	LEDs	Receive signal	RSSI (in V)	
	All 4 LEDs light up	Maximum signal strength	2.5 ... 3 V	
		16k		-75 dBm
		125k		-70 dBm
		250k		-65 dBm
		500k		-60 dBm
	Yellow and 2 green LEDs light up	Very good signal	2 ... 2.5 V	
		16k		-85 dBm
		125k		-80 dBm
		250k		-75 dBm
		500k		-70 dBm
	Yellow and 1 green LEDs light up	Good signal	1.5 ... 2 V	
		16k		-95 dBm
		125k		-90 dBm
		250k		-85 dBm
		500k		-80 dBm
	Yellow LED lights up	Low signal	1 ... 1.5 V	
		16k		LINK
		125k		LINK
		250k		LINK
		500k		LINK
	OFF	Not connected	0 V	

LED bar graph - light sequence

The light sequence from bottom to top signalizes a firmware update or that the wireless module is in write mode for the memory stick (see Section 7.6).



Observe the maximum permissible emitted transmission power of 30 dBm. This is determined based on:
 Device transmission power + Antenna gain - Cable attenuation.
 Reduce the device transmission power, if necessary.



The antenna is mounted outside the control cabinet/building. Observe the installation instructions for the antenna used. See also "Safety regulations and installation notes".

As the full transmission power and the reception amplifier are activated by default, signals may be superimposed. Increase the distance between devices.

TX LED

The green TX LED indicates communication (transmit data) with the RS-232/RS-485 interface.

RX LED

The green RX LED indicates communication (receive data) with the RS-232/RS-485 interface.

SET button

The SET button is used to confirm a station change, without performing a power up.

After making any change, press the SET button for one second to apply the settings. The DAT LED starts flashing. When the DAT LED is permanently on this means that read in has been completed.

Station changes include:

- Changing the RAD ID address of the wireless module.
- Changing the I/O MAP address of the extension modules.
- Adding an I/O extension module.
- Removing an I/O extension module.
- Using the SATEL-LP-CONF1 or SATEL-LP-MEMORY stick.

RSSI LED bar graph

In a point-to-point connection, the LED bar graph is active on the master and on the repeater/slave. The same signal strength is displayed on both modules.

In a wireless network with more than one repeater/slave, only the yellow LED on the master is permanently on. The signal strength is displayed on the repeaters/slaves. The signal strength is always related to the wireless module which is directly connected.

RF link relay

The RF link relay in the transceiver diagnoses the state of the wireless connection. It picks up when the wireless connection is established. If no data packets are received correctly over a period of 10 seconds, the relay drops out again. It picks up again automatically when the wireless connection is re-established.

The RF link relay has been designed as a PDT contact.



The RF link relay can be used as a fault message contact to indicate the failure of the wireless connection to the controller.



When the wireless module power supply is 19.2 - 30.5 V DC, up to 32 different I/O extension modules can be connected. When the power supply is 10.8 - 17.0 V DC, up to four I/O extension modules can be connected. The I/O extension modules must only be mounted to the right of the wireless module.



When using the SATEL-LP9 in a connection station, use the supplied 17.5 mm wide DIN rail connectors.

RSSI test socket

A voltage measuring device can be connected to the RSSI test socket to measure a voltage, which provides information about the received wireless signal. Using the table shown below the LED bar graph, the received signal strength can be determined using the voltage value. This can be useful when positioning and aligning the antenna, for example.

6.4 Assembly/removal

Connection station with I/O extension modules

Up to 32 different I/O extension modules can be connected to each SATEL-LP9 wireless module via the DIN rail connector (see accessories). Data is transmitted and power is supplied to the I/O extension modules via the bus foot.

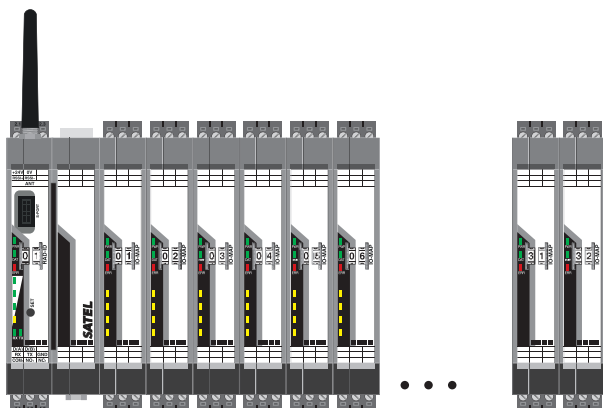

Figure 4 Radio connection station with up to 32 I/O extension modules

DIN rail mounting



Make sure that the DIN rail connector and device are aligned correctly.
 – DIN rail connector (plug) left
 – Device (snap-on foot) below

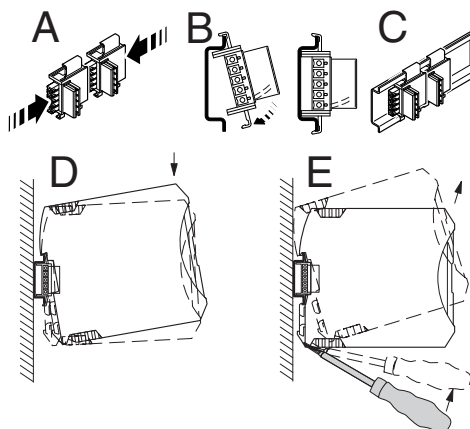

Figure 5 Mounting and removal

1. Place the device onto the DIN rail from above so that the upper housing keyway hooks onto the top edge of the DIN rail.
2. Rotate the device toward the DIN rail so the device bus connector is securely mated with the DIN rail connector.
3. Once the foot snaps onto the DIN rail, check that it is fixed securely.

DIN rail removal

1. Use a suitable screwdriver to release the locking mechanism on the snap-on foot of the device.
2. Rotate the bottom of the device off the DIN rail.
3. Carefully lift the device off the DIN rail connector and the DIN rail.

6.5 Connecting the cables

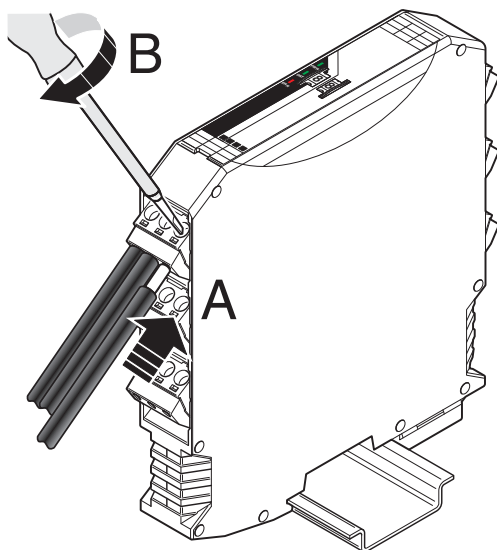

Figure 6 Connecting the cables

- Crimp optional ferrules to the wires. Permissible cable cross section: 0.2...2.5 mm².
- Insert the wire with ferrule into the corresponding connection terminal block.
- Use a screwdriver to tighten the screw in the opening above the connection terminal block. Tightening torque: 0.6 Nm

6.6 Serial pin assignment

Connect the I/O device to the SATEL-LP9 wireless module via the necessary serial interface.



Parallel operation of the interfaces is not possible.

Shielding

Connect the shield of the RS-485 bus cable correctly via an external shield connection clamp.

Choose the type of shield connection according to the type of interference expected:

- Connect the shield on one side to suppress electrical fields.
- To suppress disturbances caused by alternating magnetic fields, connect the shield on both sides. When doing so, the ground loops must be taken into account: galvanic disturbances along the reference potential can interfere with the useful signal, and the shielding effect is reduced.
- If several devices are connected to a single bus, the shield must be connected to each device (e.g., by means of clamps).
- Connect the bus shield to a central PE point using short, low-impedance connections with a large surface area (e.g., by means of shield connection clamps).



NOTE:

Observe the polarity of the RS-485 2-wire cable and ensure that the shield connection is connected correctly.

A faulty connection of the shield in combination with permanent external interferences can cause damage to the RS-485 interface.

Activating/deactivating the termination network

The SATEL-LP9 wireless module is operated on a 2-wire bus cable. For correct operation of the bus system, termination networks are required for the RS-485 bus connection. The RS-485 cable must be terminated at both ends of the bus with a 390/150/390 Ω termination network. Depending on the position of the device on the RS-485 cable, this can be implemented as shown in the table below.

Operating mode of the wireless module

The operating mode of the device is set using a termination network depending on the location on the RS-485 bus cable. Select the required operating mode and set it using the DIP switch.

Operating mode	DIP switch		
	Termination network	1	
RS-485 termination device	activated	ON	ON
RS-485 device	deactivated	OFF	OFF

RS-485 pin assignment

In RS-485 mode, an RS-485 network with several I/O devices can be created. Use a twisted pair bus cable to connect the I/O devices. Fit this bus cable with a termination network at the two furthest points of the RS-485 network.

Connect the individual conductors of the data cable to the plug-in screw terminal block.

In RS-232 mode, point-to-point connections can be established.

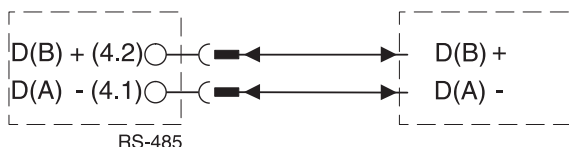

Figure 7 RS-485 interface pin assignment

RS-232 pin assignment



The RS-232 interface is a DCE (data communication equipment) type.

Connect the individual conductors of the data cable to the plug-in screw terminal block.

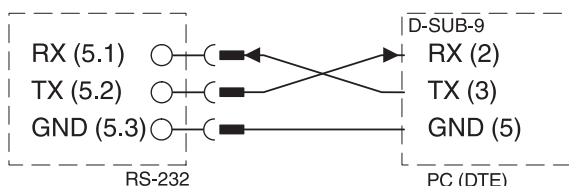

Figure 8 RS-232 interface pin assignment (DCE - DTE)

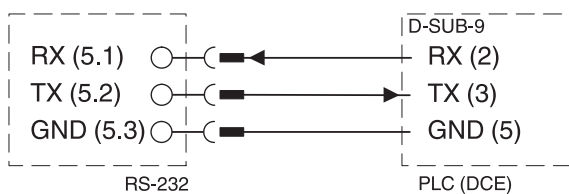

Figure 9 RS-232 interface pin assignment (DTE - DCE)

D-SUB 9 pin assignment

The SATEL-LP9 provides a D-SUB 9 female connector for attaching RS-232 serial devices.

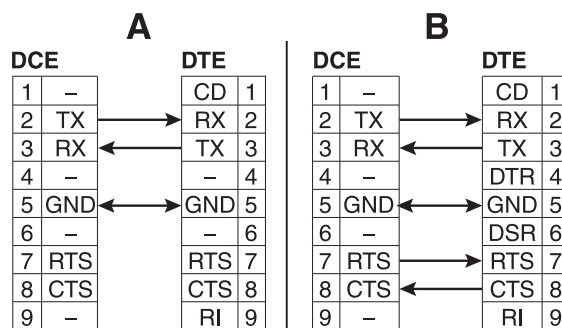

Figure 10 D-SUB 9 straight-through cable pinouts for 3-wire (A) and 5-wire (B)

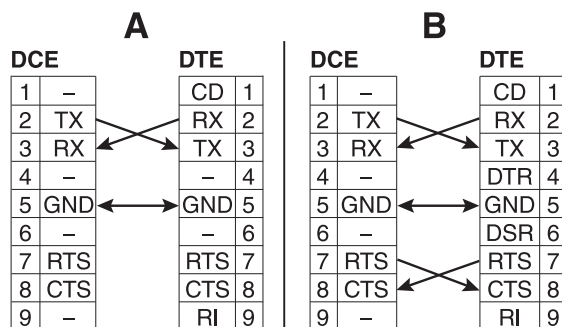

Figure 11 D-SUB 9 null cable pinouts for 3-wire (A) and 5-wire (B)

Antenna connection

The SATEL-LP9 wireless module has an RSMA antenna connection (socket) for connecting an external antenna.

A wide selection of antennas and antenna cables can be found in the "Ordering data" section on page 3.

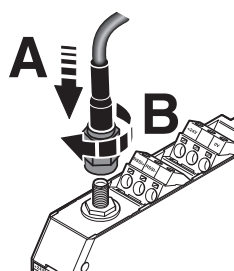

Figure 12 Antenna connection

7 Startup and configuration

All SATEL-LP9 wireless modules have the same default configuration.

Default settings

Operating mode: I/O data mode (wire in/wire out)



Data communication is only possible using I/O extension modules.

Wireless interface

Net ID: 127
 RF band: 1
 Encryption: OFF
 Network structure: Star
 Device type: Slave
 Blacklisting:
 Data rate of the wireless interface: 125 kbps
 Transmission power: 1 W (30 dBm)

For simple I/O data applications (wire in/wire out), addressing is carried out easily using a thumbwheel. You can therefore establish a wireless connection to other SATEL-LP9 devices without any programming effort.



If multiple systems are to be operated in parallel or another system is nearby, the SATEL-LP-CONF software should be used to change the network IDs so the systems cannot communicate with each other.

For serial data transmission, PLC/Modbus RTU mode or changes to the “default settings”, each wireless module must be configured using the SATEL-LP-CONF configuration and diagnostics software. See Section 7.9, “SATEL-LP-CONF configuration and diagnostics software”.

7.1 Resetting to the default settings

1. Disconnect the device from the supply voltage.
2. Press the "SET" button on the front of the device.
3. Switch the supply voltage back on.
4. Press and hold the "SET" button until the "DAT" LED flashes.

Alternatively, you can reset the device to the default settings using the SATEL-LP-CONF software.

7.2 Setting the station address (RAD-ID)

The devices in a wireless network are addressed using the thumbwheel on the front of the SATEL-LP9 wireless module. Set the desired station address with the yellow thumbwheel on the wireless module. This results in an initial functional configuration. There must be one master (address “01”) and at least one repeater/slave (address “02 to 99”) in a network.



Each address in a network must be unique.

Configuring two wireless modules with the same address will result in a network that does not function correctly.

The following settings can be made using the thumbwheel:

Thumbwheel settings	Description
01	Master address for networks with repeaters (mesh networks)
02 - 99	Repeater/slave addresses for networks with repeaters (mesh networks)
*1	Master address for networks without repeaters (star networks)
*2 - *9	Slave address for networks without repeaters (star networks)
00	Not permitted
**	Addressing wireless modules using the SATEL-LP-CONF configuration and diagnostics software (address 1 ... 250)



Setting the address via the thumbwheel has priority over setting the address via the SATEL-LP-CONF configuration and diagnostics software.



After making any change to the module address, press the "SET" button for one second to apply the setting.

7.3 I/O data transmission

In order to enable the transmission of signals, you must assign a corresponding output module to the input module.

The following conditions must be met:

Wireless module in I/O data mode (default setting)

Use the white thumbwheel on the I/O extension module to set the I/O MAP address (01 ... 99).

The input device must be provided with the same I/O MAP address as the assigned output device at the other wireless station (I/O mapping).

The I/O MAP address may only appear once in the network.

Exception: Outputs with the same address can occur multiple times in different stations on the network.

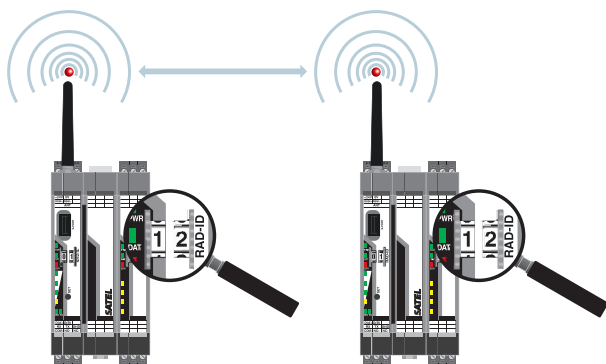

Figure 13 Example: Two SATEL-LP-DAIO6 with the same address

Once the desired number of I/O extension modules have been connected to the wireless module via the DIN rail connector, the active configuration of the station must be read in via the "SET" button (item 6 in Figure 1) on the front of the wireless module.



After making any change to the I/O MAP address (I/O extension module), you must press the "SET" button on the wireless module to apply the configuration.
 After making any change to the station (e.g., I/O MAP address, RAD ID address, adding or removing an I/O extension module, etc.), you must press the "SET" button on the wireless module for 1 s to apply the configuration.



Connect a maximum of 32 I/O extension modules if the power supply is 19.2 - 30.5 V DC.
 Connect a maximum of 4 I/O extension modules if the power supply is 10.8 - 17 V DC.

7.4 Serial data transmission

For serial data communication, the SATEL-LP-CONF software **must** be used to activate the "serial data" mode. Set the interface parameters of the RS-232 or RS-485 interface, such as data rate, parity, stop bits, and data bits, according to the connected application.

For configuration, you need the SATEL-LP-PROG cable (Order No. YC0520).

7.5 PLC/Modbus RTU mode

For configuration, you need the SATEL-LP-PROG cable (Order No. YC0520).

Activate the PLC/Modbus RTU mode in the SATEL-LP-CONF software.

In PLC/Modbus RTU mode (I/O to serial), you can wirelessly connect I/O modules directly to a controller. The wireless module provides an RS-232 or RS-485 interface for this purpose.

In PLC/Modbus mode, the wireless master works as a Modbus slave and has its own Modbus address. The Modbus address is a unique address, which is only assigned for the wireless master (RAD-ID = 1). You can select an address 1 ... 247.

You can connect I/O extension modules to each wireless device in the network. A wireless network can have a maximum of 99 I/O extension modules. Each I/O MAP address may only appear once in a network.

Use the white thumbwheel on the I/O extension module to set the I/O MAP address (01 ... 99).

Output modules and input modules must have different I/O MAP addresses with one exception: output modules with the same address can occur multiple times in different stations on the network.

Input and output data is stored in a Modbus Memory Map in the master wireless module.

The process data tables can be found in the I/O extension modules' data sheets.

7.6 Behavior of the input and output modules in the event of an interrupted wireless connection

DIP switches on the I/O extension modules can be used to set how the analog and digital outputs should behave in the event of interrupted wireless connection.

"HOLD" DIP switch

If the wireless connection is interrupted, the outputs of the I/O extension modules retain their last value or state.

"RESET" DIP switch

If the wireless connection is interrupted, the outputs of the I/O extension modules are reset (output value is set to 0).

7.7 Saving the wireless network

Use the SATEL-LP-CONF1 stick (see accessories in the "Ordering data" section on page 3), you can configure a unique and secure network. This enables the parallel operation of multiple networks (using different RF bands).

The SATEL-LP-CONF1 stick is inserted in the S-PORT (item 4 in Figure 1) of the SATEL-LP9 wireless module. Once applied, the information is loaded in an internal memory.



WARNING: Explosion hazard

Do not insert or remove the SATEL-LP-CONF1 stick or any memory stick in a potentially explosive atmosphere.



You have to configure each individual network device. To this end, you only need one SATEL-LP-CONF1 stick for all wireless modules in the network.

After configuration, you can remove the SATEL-LP-CONF1 stick from the wireless module.

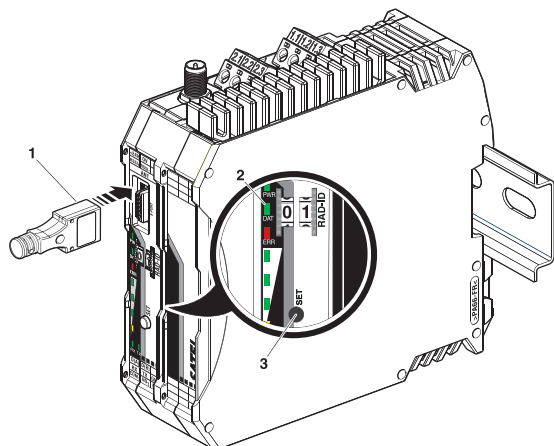

Figure 14 Configuration via SATEL-LP-CONF1 stick

- 1 SATEL-LP-CONF1 stick
- 2 Status LEDs
- 3 "SET" button

The SATEL-LP-CONF1 stick contains a unique network ID. The SATEL-LP-CONF1 stick is used as a network key.

Device configuration transfer using the SATEL-LP-CONF1 stick

1. Insert the SATEL-LP-CONF1 stick in the S-PORT of the SATEL-LP9.
2. Press the "SET" button on the device for 1 second to start the parameter transfer.
3. When the DAT LED flashes once, the transfer process is complete. The new parameters are activated.
4. Remove the SATEL-LP-CONF1 stick from the SATEL-LP9.

7.8 Copying device settings to new network devices

Your individual configuration data can be saved to a memory stick (SATEL-LP-MEMORY, see accessories in the "Ordering data" section on page 3), e.g., to transfer the same configuration to other devices.

Common network parameters:

- Operating mode
- Network ID
- RF band
- Data rate of the wireless interface
- Encryption
- Network type

Individual device parameters:

- Station name
- RAD ID
- Transmission power
- List of permitted connections
- Serial interface parameters

Writing a full copy of the individual device parameters and common network parameters to the memory stick (SATEL-LP-MEMORY):

1. Press and hold the "SET" button on the SATEL-LP9 for at least six seconds. The four RSSI bar graph LEDs start a light sequence from bottom to top.
2. Insert the memory stick in the S-PORT of the device. The copying of the parameters starts automatically.
3. Wait until the RSSI bar graph LEDs reach the static state or the light sequence stops, indicating the write process is complete.
4. Remove the memory stick from the SATEL-LP9.

Reading in common network parameters via the memory stick:

This function enables common network parameters to be read in from the memory stick. This means that all network devices can have the same network parameters.

1. Insert the memory stick in the S-PORT of the SATEL-LP9.
2. Press the "SET" button on the device for 1 second to start the parameter transfer.
3. When the DAT LED flashes once, the transfer process is complete. The new parameters are activated.
4. Remove the memory stick from the SATEL-LP9.

Reading in a full copy of the individual device parameters and common network parameters via the memory stick:

This function enables all individual device parameters and common network parameters to be read in from the memory stick. This means that a full copy of devices can be created. This can be used, for example, to create a backup copy of a device for device replacement.

1. Insert the memory stick in the S-PORT of the device. The copying of the parameters starts automatically.
2. Press and hold the "SET" button on the SATEL-LP9 for at least six seconds. The DAT LED flashes to indicate the transfer is started.
3. When the DAT LED stops flashing the transfer process is complete and the new parameters are activated.
4. Remove the memory stick from the SATEL-LP9.

7.9 SATEL-LP-CONF configuration and diagnostics software

Special settings for the SATEL-LP9 are made using the SATEL-LP-CONF configuration and diagnostics software. This is available to download at www.satel.com.

Use the SATEL-LP-PROG cable (Order No. YC0520) for configuration and diagnostics.

8 Application example

Thanks to a wide range of integrated functions, the SATEL-LP9 wireless module can be used in various ways for different applications.

Point-to-point connections

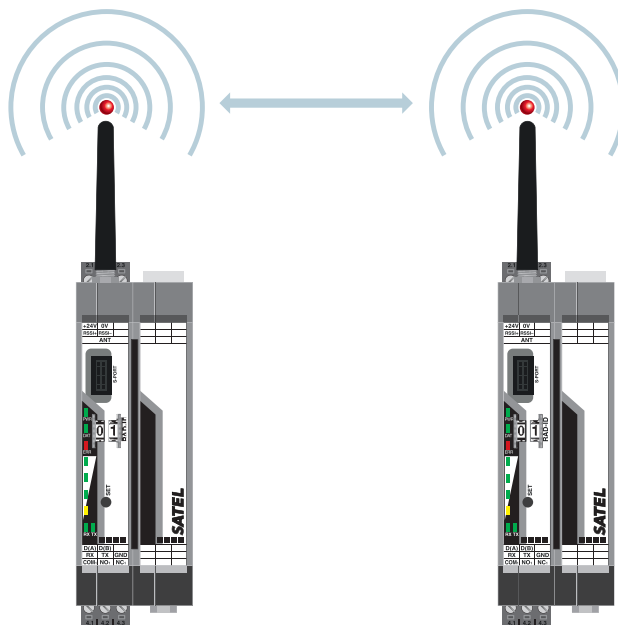

Figure 15 Example of point-to-point connection

Star network

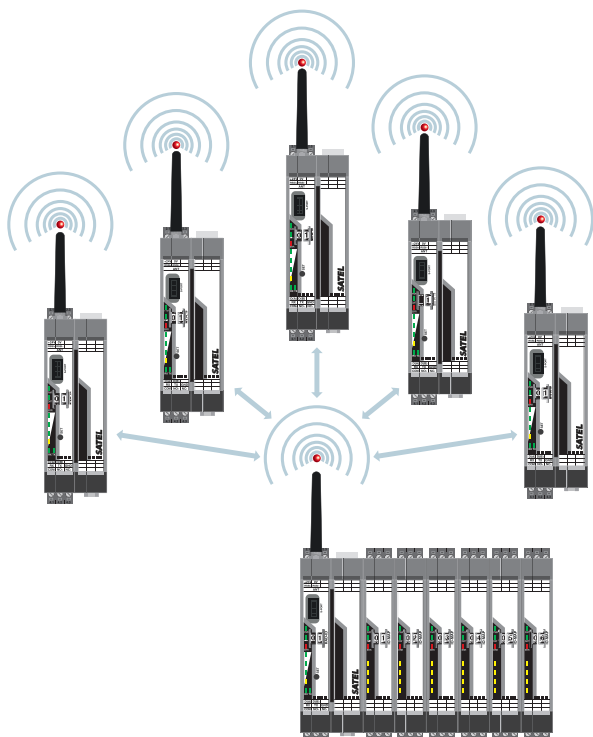

Figure 16 Example of multipoint-to-point connection

Self-healing network

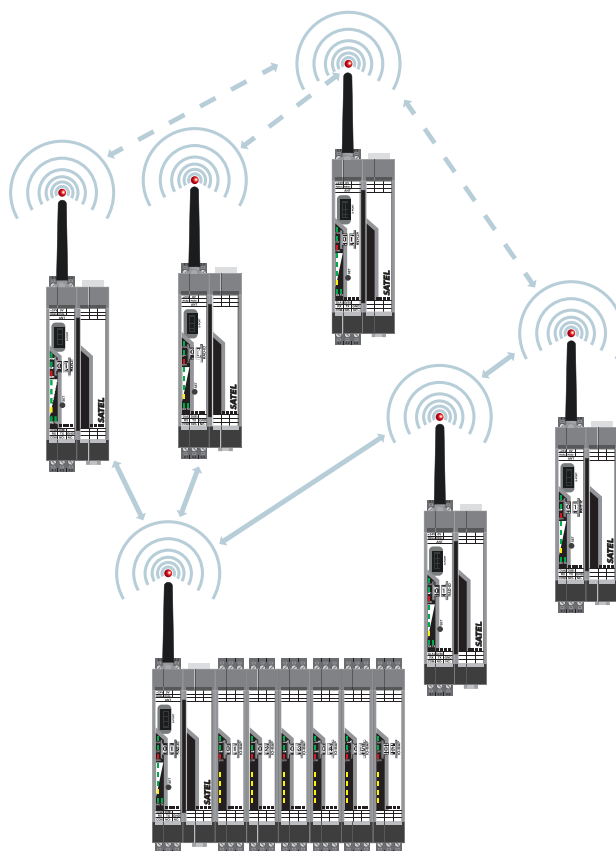

Figure 17 Example of self-healing network