

A704 Solar Medium Intensity Runway Light

The A704 meets traditional airfield requirements in an easy-to-install, low maintenance package.

- Third-party tested for ICAO and FAA compliance
- Long-lasting batteries
- Available in 3 battery sizes

Applications

- Medium-intensity runway edge & threshold (MIRL)
- Simple approach lighting
- NVG operations, covert-only mode
- Emergency or temporary lighting

Advanced Design

- Improved optical efficiency with latest LEDs
- High-efficiency monocrystalline solar panels
- Reduced standby power consumption
- Multiple battery sizes for best value-for-performance
- Optional CCR wired power interface
- Optional wireless control provides remote operation using either 900 MHz or 2.4 GHz communication

Easy Installation

Limited crew. No trenching. No airfield interruptions. Just place the A704 and it emits light dusk-to-dawn while maintaining its battery.

Low Maintenance

The A704 integrates solar panels, battery, electronics and LED light source into a compact, stand-alone unit requiring minimal maintenance for 7 years.

Reliable

The Energy Management System (EMS) monitors all operations to provide consistent output in the harshest environments. Testing to ICAO, FAA and MIL specifications ensures high performance for many years.

Trusted

With thousands of installations worldwide, Flash Technology solar LED lights operate year-round at over 500 airports and military bases.



Optional wireless control

Optional handheld controller - 900 MHz OR 2.4GHz with encrypted signal - Control 8 groups of lights

Optional military and barrel charge ports

A704

SPECIFICATIONS

Compliance	ICAO MIRL (Annex 14, Vol. 1, 5.3.9.9)
	FAA L-861 MIRL (AC 150/5345-46, EB67)
	FAA L-861E & L-861SE MIRL (AC 150/5345-46, EB67)
	FAA L-860 LIRL (AC 150/5345-46, EB67)
	FAA L-863 Portable (AC 150/5345-50)
	FAA L-858 Sign Lighting (AC 150/5345-44)
	FAA L-810 Red (AC 150/5345-43F)
	ICAO Red Low-Intensity Obstacle Light Type A and Type B (Annex 14, 5th Edition)
Optical	Red output for airport barricade and construction applications (CFR Part 139, FAA AC 150/5370-2E)
	High-powered LEDs meet IES LM-80 lumen maintenance ensuring consistent photometrics for life of product
	ICAO, SAE25050 (FAA) and FAA EB 67 compliant chromaticity
Solar Panel	NVG-compatible infrared LEDs
	Steady-on and flash, IR only mode
	High-efficiency solar cells with blocking diodes
Battery	Maximum power point tracking with temperature compensation (MPPT-TC) for optimal energy collection in all solar conditions
	Pure-lead VRLA AGM battery with manufacturer operating range -85 to 176 °F (-65 to 80 °C)
	Onboard battery status
Energy Management System (EMS)	Optional port for battery charging and cabled operation
	Designed for 5-year battery life; Replaceable and recyclable
	2500 cycles or 7-year lifetime on average
Automatic Light Control (ALC)	Intelligent, microprocessor
	Onboard diagnostics and data-logger
	Push button interface for local control
	Autonomous (dusk-to-dawn), temporary, continuous and emergency modes
Construction	When enabled, automatically adjusts to low levels of sunlight to ensure continuous operation
	Premium, UV-resistant polycarbonate lens (jet blast resistant glass lens available)
Temperature	Corrosion-resistant, powder-coated aluminum chassis with integrated handle
	Waterproof, vented battery compartment
Wind Loading	-22 to 122 °F (-30 to 50 °C) Optimal
Ice Loading	-40 to 176 °F (-40 to 80 °C) Maximum
Shock & Vibration	400 mph (644 kph)
Ingress	0.03 psi (22 kg/m ²)
	MIL-STD-202G and MIL-STD-810G
	EN 60529 IP 67 immersion
Ingress	MIL-STD-202G immersion & damp heat cycling
	MIL-STD-810G rain & salt fog

WEIGHTS AND DIMENSIONS

COMPACT
12.4 lbs (5.6 kg)
Battery (60X) - 4.2V, 15 Ahr

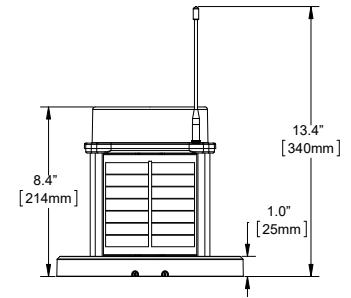

STANDARD (WITH COMPACT BATTERY)
15.3 lb (6.9 kg)
Battery (60X) - 4.2V, 15 Ahr

STANDARD
16.4 lb (7.4 kg)
Battery (96E) - 4.2V, 24 Ahr

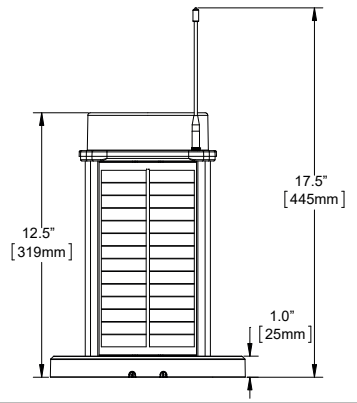

LARGE
24.5 lbs (11.1 kg)
Battery (200BC) - 4.2V, 50 Ahr

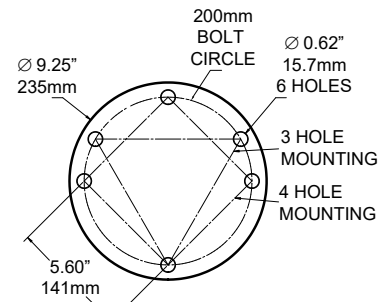

BOTTOM VIEW

CONFIGURATION

Model	Color	Battery Size
A704	White/IR	Compact Standard Large
	White/Yellow/IR	
	Red/Green/IR	
	Green/IR	
	Yellow/IR	
	Red/IR	
	White/Red/IR	
Red/Yellow/IR		
Green/Yellow/IR		
Lens	Control	Charge Port
Polycarbonate Glass	Non-wireless Wireless (900 MHz) Wireless (2.4GHz) ASK CCR	None Charge Port Military Charge Port CCR



FLASH TECHNOLOGY

flashsales@spx.com | flashtechnology.com/airfield | 1.615.503.2000

©2019 Flash Technology. All rights reserved. Data and specifications subject to change without notification. ISO 9001:2015. DA704-01 Rev B