

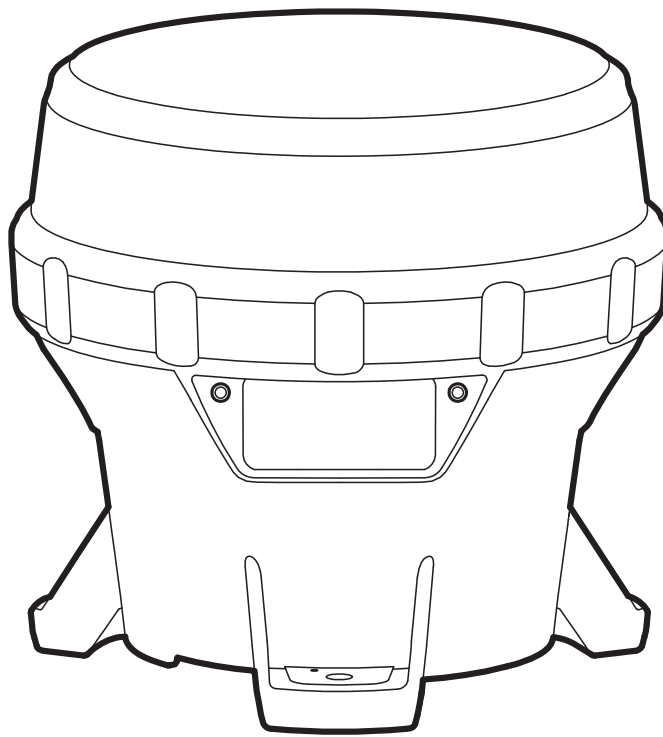

carmanah®

OL4 OBSTRUCTION LIGHT

USER MANUAL



Technical Support:

Email: customerservice@carmanah.com

we put solar to work™

Warnings and Precautions

The following symbols indicate important safety warnings and precautions throughout this manual. They are defined as follows:



WARNING indicates that serious bodily harm or death may result from failure to adhere to the precautions.



CAUTION indicates that damage to equipment may result if the instructions are not followed.



NOTE suggests optimal conditions under which the equipment will operate effectively and safely, or provides additional information to the reader.

Regulatory Information

This Class [B] digital apparatus complies with Canadian ICES-003.

Cet appareil numérique de la classe [B] est conforme à la norme NMB-003 du Canada.



Changes or modifications not expressly approved by the party responsible for compliance could void the user's authority to operate the equipment. Installation work must be done by a qualified person(s) in accordance with all applicable local codes and standards.

Equipment shall be positioned outside the 5m vicinity of a compass as per ISO 694.



Safety and Usage Precautions



The OL4's Battery Pack contains lead, lead compounds, and other compounds known to the State of California to cause cancer and reproductive harm. Please handle with care and wash your hands thoroughly after handling the Battery Pack.



Charge your OL4's Battery Pack periodically. Permanent damage and reduced capacity will result if the Battery Pack is not correctly maintained. Refer to page 19 for details on how to maintain your Battery Pack.

OL4s that have been stored will usually require a top-up charge before they are put into service. The most accurate Battery Pack Health status reading is obtained when the OL4 has been in a dark location and in Off mode for at least 24 hours.

Warranty Disclaimer



This manual will familiarize you with the features and operation standards of Carmanah's Model OL4 lantern. Failure to comply with the use, storage, maintenance, installation or placement instructions detailed in this manual could void the applicable user warranty.

Table of Contents

Warnings and Precautions.....	2		
Regulatory Information	2	Solar Charging.....	20
Safety and Usage Precautions	2	Optional Plug-In Charger.....	20
Warranty Disclaimer	2	Charging with an Artificial Light Source	21
		Preserving Battery Pack Health	21
Introduction	5	Storage Procedures.....	22
OL4 Applications	5	Replacing the Battery Pack	22
Common Features and Functionality.....	5		
OL4 Parts Description	7	Maintenance	24
Getting Started.....	8	Recycling	25
What's in the Box?.....	8	The Battery Pack.....	25
Installing the Bird Deterrent.....	8		
On/Off Switch (Optional).....	8	Shipping.....	26
Bottom Cover Lock	9	Ship Mode.....	26
Operation	10	Appendix A: Carmanah Device Manager	
Choosing an Installation Location.....	10	Software	27
Choose a Sunny Location	10	System Requirements	27
Cooler is Better	10	Hardware Requirements.....	27
Installing the OL4.....	10	Software Requirements	27
		Installation Procedure.....	27
Configuring the OL4	11	Removing the Bottom Cover.....	28
Methods	11	Logging In	29
On-Board User Interface	11	User Functions.....	30
Removing the Bottom Cover.....	11	Checking the Light's Status	32
Status Report.....	12	Status Page	32
Editing Parameters	12	Configuration Page.....	33
Entering the Passcode	13	SW Admin Page	36
Editing the Flash Code	13	Initial Configuration.....	38
Editing the Effective Intensity	14	User Tasks	41
Editing the Automatic Light Control (ALC) mode	14	Restoring the Default Configuration	41
Resetting to Initial Settings	15	Using the Derived Values	41
Editing the Date	15	Entering/Exiting Ship Mode	43
Setting the Calendar Function	16	Setting the Time	44
Installing the Bottom Cover	17	Setting the Day to Night Transition Level.....	44
Device Manager Software	18	Setting the Night to Day Transition Level.....	45
On/Off Switch	18	Setting the ALC.....	45
Off Mode.....	18	Changing the Device Manager Password	46
Standard On Mode	18	Understanding the Installation Location	
Fog Mode.....	19	Environmental Parameters	46
Infrared Remote Programmer (Optional).....	19	Distributor Functions.....	47
		Logging In	47
Battery Pack	20	Configuring the OL4	48
Battery Pack Health Status.....	20	Entering the Deployment Location	48
Charging the Battery Pack.....	20	Setting the User's Device Access	49

Downloading a Configuration	49
Sending a Configuration to a Light	49
Creating a Configuration File	50
Reading a Configuration File	50
Retrieving a Light's Configuration	51
Saving a Configuration File	51
Changing Passcodes	52
Updating the Firmware	52
Updating the Flash Code Table	53
Retrieving a Datalog	55
Appendix B: Using the Infrared Remote Programmer	56
Entering the Passcode	56
Changing the Flash Code	57
Turning the OL4 Off	57
Setting the OL4 to Ship Mode	58
Restoring the OL4 from Ship Mode	59
Determining the Battery Pack's State of Health ..	59
Appendix C: Ordering Codes	60
OL4 Accessories	60
Appendix D: Specifications	61
Form-Factor	61
Optical	61
Energy Capture	61
Energy Storage	61
User Interface	61
Standards and Testing	61
Standards and Testing (continued)	62
Patents	63
Mounting	63
Photometric Plots	64
Appendix E: Flash Codes	65
Appendix F: Warranty and Customer Service Information	74
Warranty	74
Customer Service	74

Introduction

OL4 Applications

The **OL4 Hazard Marker** is a rugged, multi-purpose light for marking barricades, fencing, entranceways, and ground hazards at industrial sites, construction areas and other hard-to-access locations.

Common Features and Functionality

The OL4:

- Is a self-contained, high-performance, low-maintenance and easy-to-install solar-powered light source.
- Is programmed for geographical location to optimize output and prevent a user from potentially damaging the product.
- Is suitable for a range of hazard marking applications.

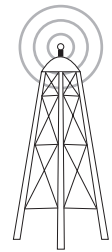

- Is durable and reliable with double o-ring sealing.
- Offers dusk-to-dawn operation with programmable transition levels.
- Features a replaceable Battery Pack.

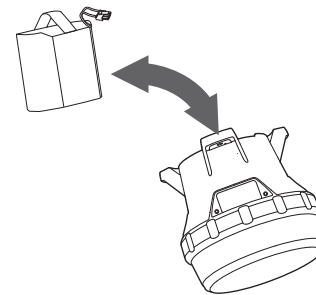

- Has a removable Bottom Cover for accessing the On-Board User Interface (OBU).
- Has an efficient optical design.
- Has over 250 user-programmable flash patterns.

- Has four different user interfaces:
 - On Board User Interface (OBU)

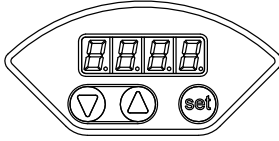

- (Optional) On/Off Switch

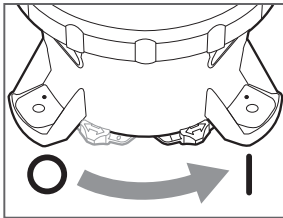

- (Optional) Infrared Programmer

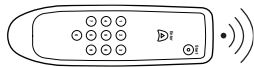

- Carmanah Device Manager software, via USB cable

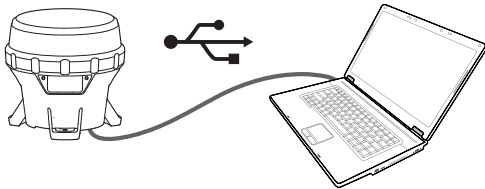

- Has multiple layers of programmable password protection.
- Is available in red, green, yellow, white and blue LED output colours.
- Is designed in accordance with the European Union's guidelines for the Restriction of Hazardous Substances in electronic equipment (RoHS).



OL4 Parts Description

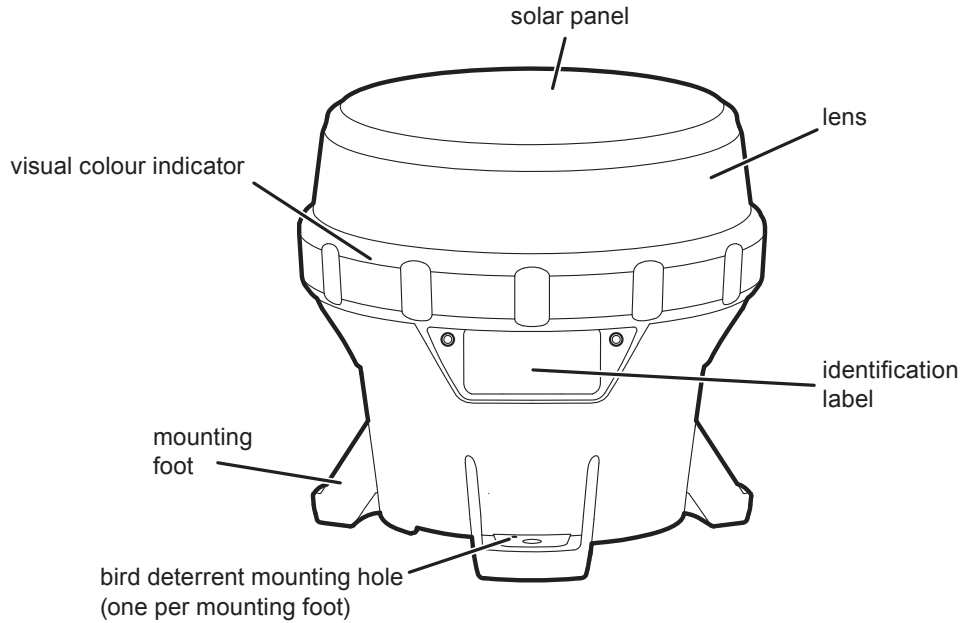

SIDE VIEW

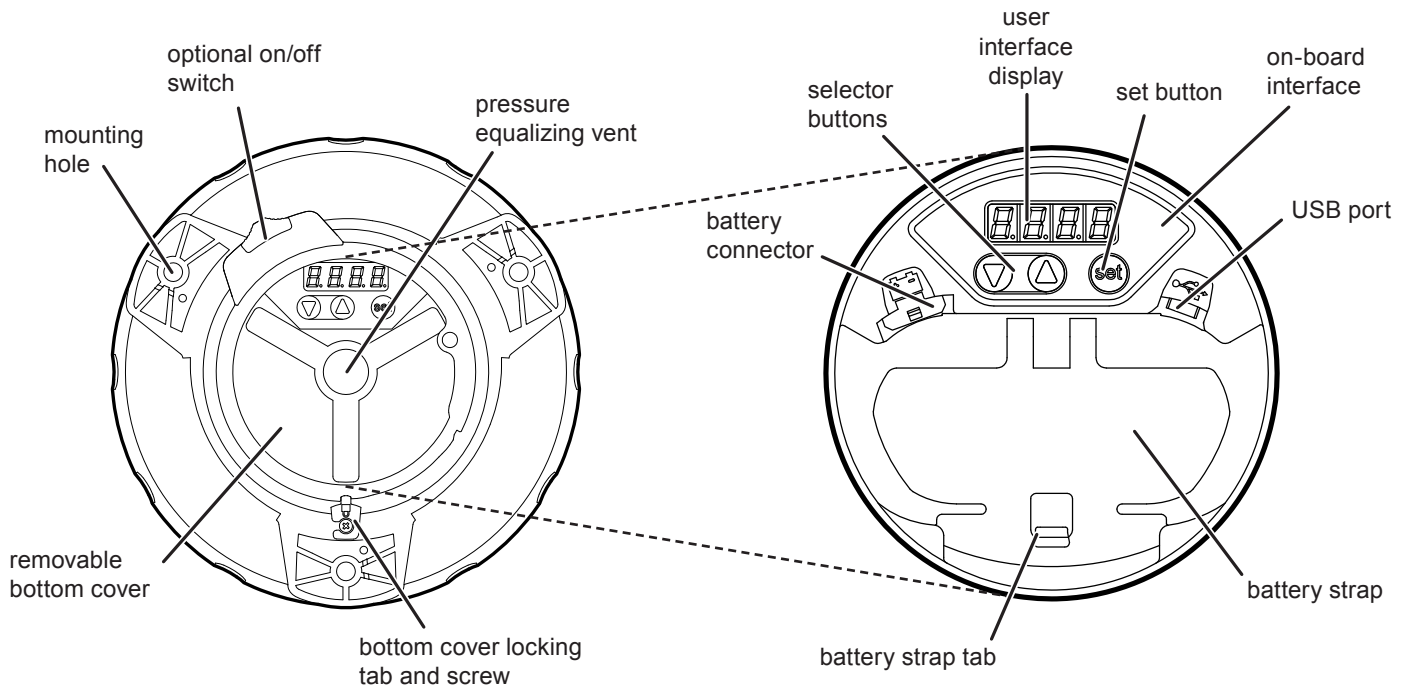

BOTTOM VIEW

INTERNAL VIEW
(BOTTOM COVER REMOVED)

Getting Started

What's in the Box?

The OL4 ships in a small cardboard box. Each box contains:

- One OL4 light.
- One Bird Deterrent.
- One illustrated Quick Start Guide.

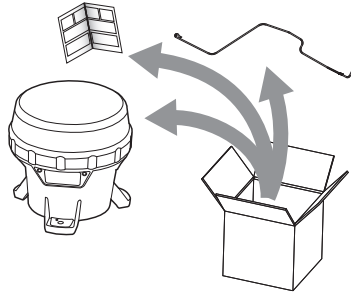

NOTE

The OL4 User Manual (this document) is shipped independently of the OL4. It is also available for download on Carmanah.com.

Installing the Bird Deterrent

Included with each OL4 is one Bird Deterrent. If bird fouling of the OL4 is a concern in your installation environment, install the Bird Deterrent as follows:

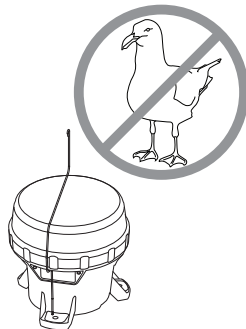

1. Insert the short L-shaped end through the small hole in the top of one of the OL4 mounting feet.

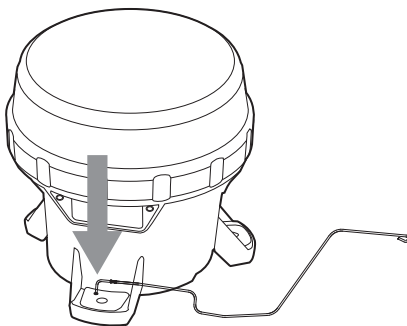

2. Rotate the wire upwards 90 degrees until it is in the upright position.

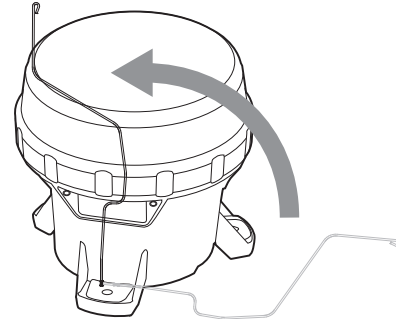

3. Twist the Bird Deterrent clockwise until the L-shaped end snaps into the groove on the bottom of the mounting foot. The Bird Deterrent extends over the top of the OL4 to prevent birds from landing on the OL4.

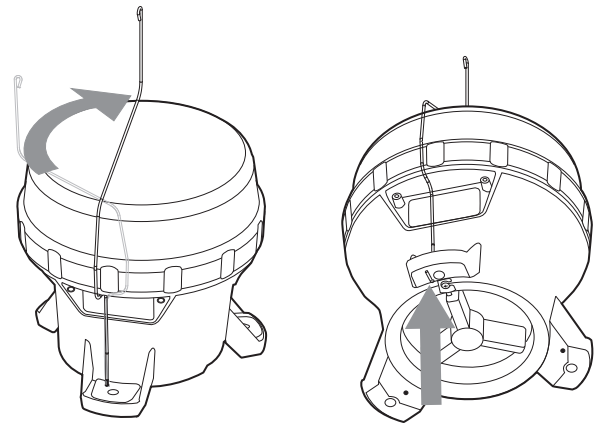

NOTE

The OL4 can be fitted with up to three bird deterrents.

On/Off Switch (Optional)

The OL4 is available with an optional On/Off Switch which is located on the OL4's Bottom Cover. The On/Off switch allows you to:

- Shut off the LEDs (while allowing the OL4 to continue charging).
- Activate Standard On (Dusk-to-Dawn) or Fog Mode.
- Initiate a Status Report (see page 12) without having to remove the Bottom Cover.

When switched off, the OL4 remembers its Flash Code, intensity, and other settings.

NOTE

With the switch in the Off position, the OL4's LED will not turn on, and it will not respond to commands from the IR Remote. The OL4 will, however, charge its Battery Pack when exposed to sunlight, regardless of the position of its switch.

on/off switch

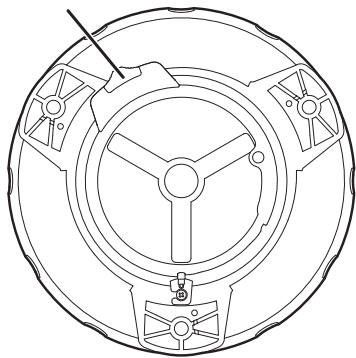

The switch has two positions, **On** (I) and **Off** (O).

1. To put the switch in the **On** position, slide the switch to the right until it snaps into position. In the **On** position, a "I" symbol is visible on the switch.

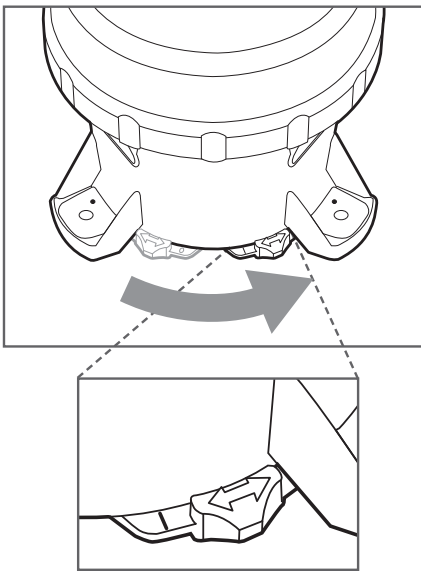

2. To put the switch in the **Off** position, slide the switch to the left until it snaps into position. In the **Off** position, a "O" symbol is visible on the switch.

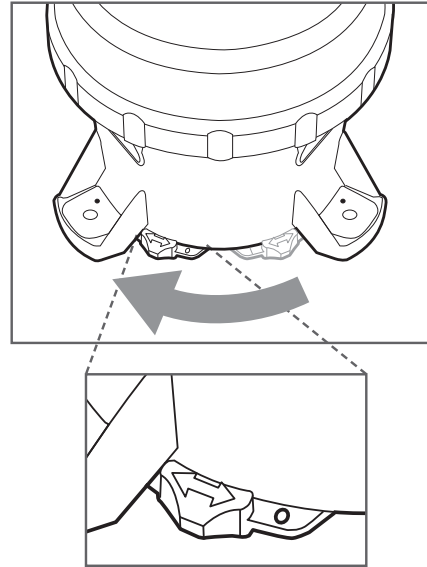
NOTE

Removing the bottom cover is equivalent to placing the switch in the **On** position.

Bottom Cover Lock

You can lock or unlock the OL4 Bottom Cover by tightening or loosening the locking screw from the tab on the Bottom Cover. Tightening the screw renders the Bottom Cover tamper-proof when it is installed against a flat surface using security fasteners.

NOTE

To unlock the Bottom Cover, loosen the screw; it does not need to be fully removed.

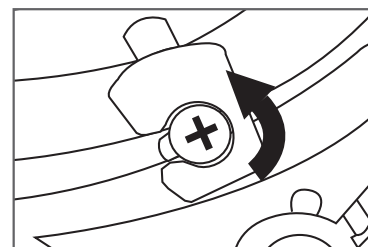

Operation

Choosing an Installation Location

NOTE

Full solar exposure is critical to the OL4's long-term performance. Ensure that the installation location has year-round, unrestricted sun exposure throughout the day.

Choose a Sunny Location

During the winter, the sun is lower on the horizon. Because the angle of the sun changes with the seasons, you must be aware that obstructions such as trees, buildings, and mountains that do not shade the OL4 during the summer may shade it during the winter. Choose your installation location very carefully to prevent this situation, because shade dramatically reduces the ability of the OL4 to charge its Battery Pack.

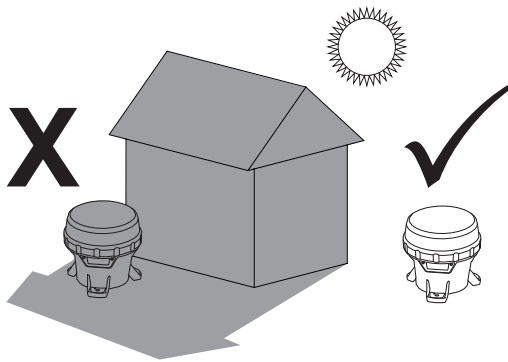

Cooler is Better

The OL4 Battery Pack lasts longest if you can minimize its exposure to high temperatures. Choose a location that is away from hot, dark coloured surfaces, like asphalt or black steel plate. Carmanah offers mounting kits that can help reduce the temperature of your Battery Packs, allowing longer replacement intervals.

Installing the OL4

The OL4 has three mounting feet with holes for ¼" (M6) fasteners (fasteners are not included, and can be ordered as an optional kit). The three holes are 120° apart, and have a bolt circle diameter of 5.9" (150mm). You can use these holes to mount the OL4 to a variety of surfaces.

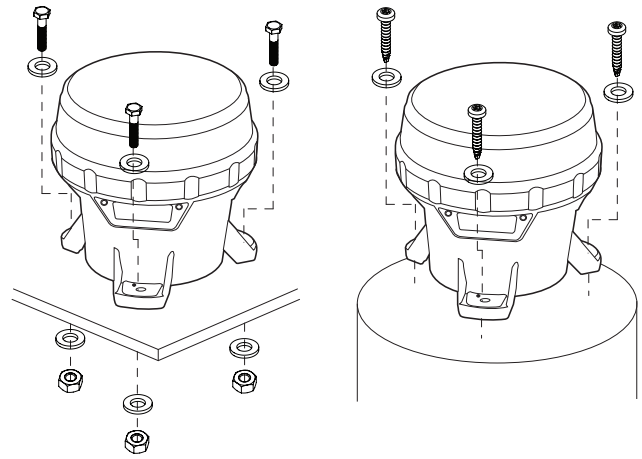

Ensure the mounting surface is flat and level. The surfaces in contact with the three mounting feet must be flat to within 0.120" (3 mm) of one another or the OL4 chassis could twist when tightened down.

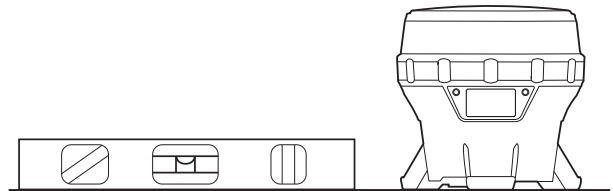

Torque the mounting fasteners to a minimum of 4 ft-lb (5.4 N-m).

NOTE

Carmanah has various OL4 mounting kits available. Please visit Carmanah.com or contact a Carmanah distributor or sales representative for more information on purchasing one of these kits.

Configuring the OL4

Methods

You can program the OL4 using:

- The **On-Board User Interface (OBUI)**. Refer to the following section for detailed information about using the OBUI. Note that you must remove the Bottom Cover to access the OBUI buttons.
- The **Carmanah Device Manager software**. Detailed information about using the Carmanah Device Manager software is located in Appendix A. Note that you must remove the Bottom Cover to access the USB port and use the Carmanah Device Manager software.

NOTE

Typically, a Distributor uses the Carmanah Device Manager software to configure your OL4. Using the Carmanah Device Manager software, the Distributor can program a configuration, set the installation location environmental parameters, change passcodes, update firmware, etc.

You can perform some basic configuration using:

- The optional **On/Off Switch**. Detailed information about using the On/Off Switch is located on pages 8 and 18 of this document. You do not have to remove the Bottom Cover to use the On/Off Switch.
- The optional **Infrared Remote Programmer (IR Remote)**. Detailed information about using the IR Remote is located in Appendix B. You do not have to remove the Bottom Cover to use the IR Remote.

On-Board User Interface

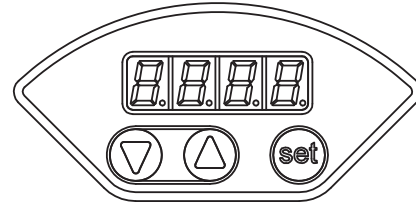

You can use the On-Board User Interface (OBUI) to configure many of the light's parameters and features. To use the OBUI to configure the OL4, first remove the Bottom Cover.

Removing the Bottom Cover

Removal of the Bottom Cover is required to configure the OL4 using the OBUI.

1. Turn the OL4 upside down and place it on a soft cloth (to avoid scratching the housing).

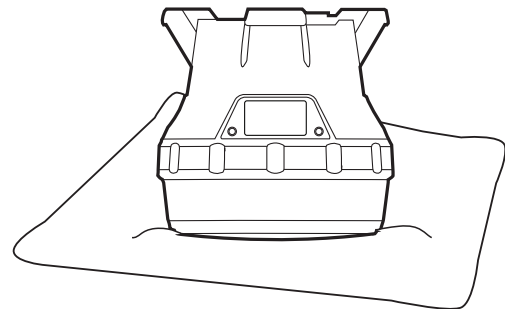

2. Locate and turn the locking screw counter-clockwise to allow the locking tab to clear the screw head (you do not have to remove the locking screw).

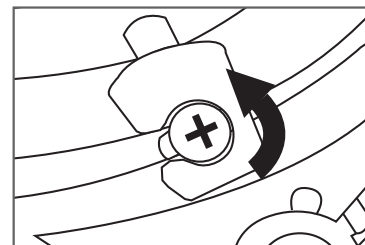

- Secure the OL4 so it won't move, and then firmly twist the Bottom Cover counter-clockwise until it stops.

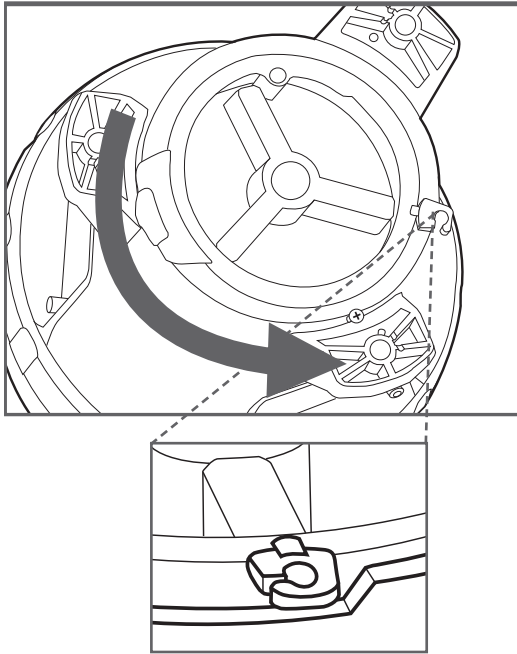

- Lift the cover out by pushing up on the protruding locking tab. You now have access to the OBUi buttons or the USB connector port (for using the Carmanah Device Manager software). This is also the first step when replacing the Battery Pack.

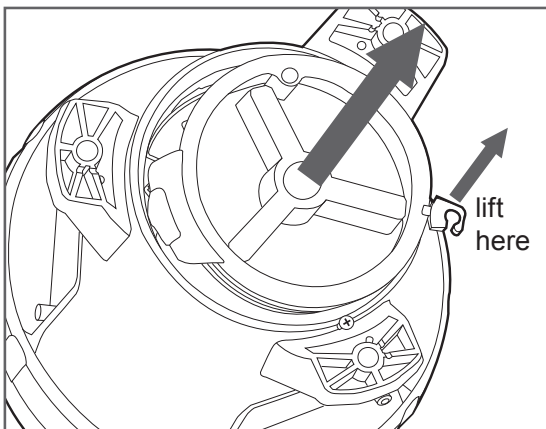

Status Report

After you remove the Bottom Cover, you can use the OBUi to query the status of various OL4 parameters (without editing them) by pressing and briefly holding one of the three buttons under the display.

The display then reports the following parameters:

- batt:** Battery Pack health status (pg. 20)
- FLSH:** programmed Flash code (pg. 13)
- Int:** programmed effective intensity (in candela) (pg. 14)
- ALC:** Automatic Light Control (ALC) state - **on** or **off** (pg. 14)
- Date:** current date (pg. 15)
- Info:** programmed firmware version (pg. 32)
- Lat:** programmed latitude setting (pg. 46)
- Long:** programmed longitude setting (pg. 46)

After the parameters have finished scrolling, **Hold Set to Edit** will appear on the display. The display will then repeat the status report, finishing with **Hold Set to Edit**. The display will then turn off.

NOTE

By pressing the up/down arrow buttons, you can scroll through the parameters at your own pace. The display will turn off after 60 seconds of button inactivity.

Editing Parameters

To edit any of the parameters, press and hold the set button for approximately one second. After entering the passcode (see the next section), you will be able to edit parameters as described in the sections that follow.

NOTE

For models equipped with the optional external switch, moving the switch from the **Off** to the **On** position will initiate a status report. A status report will also result if the switch is in the **Off** position, and the Bottom Cover is removed.

Entering the Passcode

Before you can edit any of the OL4's parameters, you must enter a Passcode. The default Passcode is **753**.

To enter the Passcode:

1. Press and hold the **set** button for approximately one second. The words **Pass Code** briefly display on the OBU, followed by three zeroes with the left zero flashing. The display is prompting you to enter the Passcode beginning with the first digit.
2. Enter **753** on the display. Use the arrow buttons to change the number, and press the **set** button briefly to advance to the next digit.
3. When **753** displays, press and hold the **set** button again for approximately one second. **753** flashes quickly to indicate that you have successfully entered the Passcode and are now logged in to the OBU. Use the arrow buttons to scroll through the editable fields.

NOTE

You can change the Passcode using the Carmanah Device Manager software (Appendix A). This is recommended to improve OL4 security.

NOTE

If you do not edit any of the settings, the OBU exits the edit mode after two minutes. Your Carmanah Distributor can also configure the OL4 so that entering a Passcode is not required. Contact your distributor for details.

NOTE

If you enter an incorrect Passcode, the word "Fail" briefly displays. This indicates that:

- The Passcode was entered incorrectly, or
- The Passcode has been changed from the default setting (753) using the Carmanah Device Manager software.

NOTE

As a security measure, your distributor can limit which settings can be edited using the OBU. If you are unable to edit a setting using the OBU, contact your Carmanah Distributor for assistance.

Editing the Flash Code

If you need to change the Flash Code (for example, when you have to change an OL4 to the "steady-on" Flash Code – **001**), use the following procedure:

1. Press the **set** button until the words **Pass Code** appear on the OBU display.
2. Enter the Passcode to log in to the OL4.
3. After logging in, the word **FLSH** appears on the display.
4. Press and hold the **set** button for approximately two seconds until the Flash Code setting appears in the display with the first digit flashing.
5. Use the **up** and **down** arrows to change the first digit, and press the **set** button briefly to advance to the next digit. For a list of commonly-used Flash Codes, refer to Appendix F.
6. Change each of the three digits using the same procedure.
7. When you are finished and the new Flash Code shows on the display, press and hold the **set** button for approximately one second. The code flashes three times quickly to indicate that the new Flash Code has been set. The OL4 will then demonstrate the new flash code for one minute.

NOTE

If programmed in a dim location, the OL4 will continue to flash after one minute has elapsed.

NOTE

Changing the Flash Code may reduce the effective intensity setting, if the new Flash Code cannot operate in a sustainable manner at the programmed effective intensity in the programmed installation environment.

If you program a Flash Code that requires a lower Effective Intensity setting than is currently programmed, then after accepting the new Flash Code, the display indicates the new maximum Effective Intensity, and allows it to be edited (unless the user doesn't have edit access to Effective Intensity, in which case it will program the maximum allowable Effective Intensity).

NOTE

The range of allowable effective intensities changes based on the programmed installation latitude and longitude and the Flash Code. The OL4 does not allow you to select an intensity which consumes more energy than is available from the solar panel in the programmed installation location.

NOTE

The maximum allowable effective intensity may automatically change as you program different Flash Codes. The OL4 automatically calculates a new upper limit on effective intensity based on the new Flash Code and installation location latitude and longitude.

Editing the Effective Intensity

The effective intensity of the light is a measure of its apparent brightness, and has units of candela. It takes into account the programmed Flash Code.

To change a light's effective intensity:

1. Press the **set** button until the words **Pass Code** appear on the OBUI display.
2. Enter the Passcode to log in to the OL4.
3. After logging in, press the **up** or **down** buttons until the word **Int** appears on the display.
4. Press and hold the **set** button until the intensity setting starts flashing
5. Press the **up** or **down** buttons until the correct effective intensity appears on the display.
6. Press the **set** button for approximately one second to store the change.

Editing the Automatic Light Control (ALC) mode

When ALC mode is set to **on**, the OL4 monitors the Battery Pack's state of health and reduces the intensity level if the OL4 is not receiving sufficient solar energy to maintain the Battery Pack.

If the OL4's latitude and longitude are set correctly, ALC only reduces the intensity setting for the light in unusually poor solar conditions.

To toggle the ALC setting:

1. Press the **set** button until the words **Pass Code** appear on the OBUI display.
2. Enter the Passcode to log in to the OL4.
3. After logging in, press the **up** or **down** buttons until **ALC** appears on the display.
4. Press and hold the **set** button until the current state of the ALC flashes (either **on** or **off**).
5. Press the **up** or **down** buttons to toggle ALC to **off** or **on**.

6. Press the **set** button for approximately one second to store the change.

NOTE

Set the ALC to **off** if your application demands that the OL4 meets specific intensity requirements.

NOTE

Leaving the ALC on provides prolonged Battery Pack life in the event of unusually poor weather over an extended period of time, or excessive bird fouling of the solar panel. When ALC intervenes, the LED's brightness is reduced.

Resetting to Initial Settings

Resetting to Initial Settings returns the OL4's configuration to settings that were present when you first received the OL4. If your Distributor programmed the light with specific settings for you, these are the settings that are restored.

1. Press the **set** button until the words **Pass Code** appear on the OBUI display.
2. Enter the Passcode to log in to the OL4.
3. After logging in, press the **up** or **down** buttons until the word **RSET** appears on the display.
4. Press and hold the **set** button until the word **no** flashes.
5. Press the **up** or **down** buttons until the display changes to **yes** (to restore the Distributor-programmed defaults) or **no** (to leave the settings as they are).
6. Press the **set** button for approximately one second to store the change. The word **DONE** flashes three times to indicate that the changes have taken effect.

Editing the Date

The OL4 has an internal clock which it uses for logging activity. The current date is written in non-volatile memory, so if the Battery Pack is unplugged or becomes completely discharged, but you reconnect or replace the Battery Pack within a few hours, the date remains correct. However, if the OL4 is left without power for more than a few hours, you may need to reset the date.

To edit the date on the OL4:

1. Press the **set** button until the words **Pass Code** appear on the OBUI display.
2. Enter the Passcode to log in to the OL4.
3. After logging in, press the **up** or **down** buttons until **date** shows on the display.
4. Press and hold the **set** button until the current year is flashing on the display.
5. While the year displays, press the **up** or **down** button to change it.
6. Press the **set** button briefly. The month starts to flash on the OBUI display.
7. While the month displays, press the **up** or **down** button to change it.
8. Press the **set** button briefly. The day starts to flash on the OBUI display.
9. While the day displays, press the **up** or **down** button to change it.
10. Press the **set** button for approximately one second to store the new date.

Setting the Calendar Function

The Calendar Function allows you to specify a dated shutdown and reactivation date if desired.

To toggle the calendar setting on or off:

1. Press the **set** button until the words **Pass Code** appear on the OBUI display.
2. Enter the Passcode to log in to the OL4.
3. After logging in, press the **up** or **down** buttons until "**CAL**" shows on the display.
4. Press and hold the **set** button until the display flashes "**on**" or "**off**".
5. While the status displays, press the **up** or **down** button to change it.
6. Press the **set** button for approximately one second to store the selection status.

To set the date the OL4 will enter dated shutdown:

Confirm that the calendar is turned "on".

1. Navigate to the "**Con**" menu.
2. Press and hold the **set** button until the display flashes.
3. While the month displays, press the **up** or **down** button to enter the month when dated shutdown will begin.
4. Press the **set** button briefly. The day starts to flash on the OBUI display.
5. While the day displays, press the **up** or **down** button to enter the specific day of the month when dated shutdown will begin.
6. Press the **set** button for approximately one second to store the new shutdown date.

To set the date the OL4 will reactivate:

Confirm that the calendar is turned "on".

1. Navigate to the "**CoFF**" menu.
2. Press and hold the **set** button until the display flashes.
3. While the month displays, press the **up** or **down** button to enter the month when dated shutdown will end.
4. Press the **set** button briefly. The day starts to flash on the OBUI display.
5. While the day displays, press the **up** or **down** button to enter the specific day of the month when dated shutdown will end.
6. Press the **set** button for approximately one second to store the new reactivation date.

Installing the Bottom Cover



The double o-ring seal can make the bottom cover difficult to install. Take your time, and ensure the cover goes in straight, and is properly seated before you start turning it. Press down firmly on the cover as you turn it to avoid cross-threading it.

After you have completed configuring the OL4 using the OBU, you must install the Bottom Cover:

1. Make sure that the two o-rings in the Bottom Cover are in place, are clean, and in good condition. Ensure that the inside surfaces of the OL4 that the o-rings will contact are also clean.

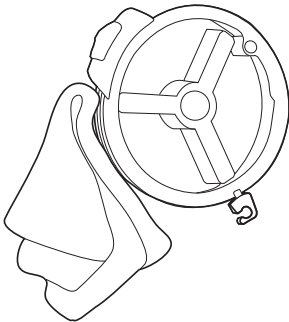

2. If the Bottom Cover was difficult to remove, apply a very thin coating of silicone o-ring lubricant to the two o-rings on the Bottom Cover before installing it.
3. To install the Bottom Cover, align it so that the protruding locking tab is aligned with the small angled wall in the light chassis.

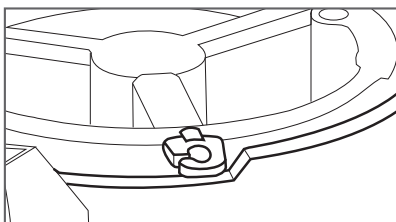

4. Push down firmly and evenly until the Bottom Cover is seated in the chassis.

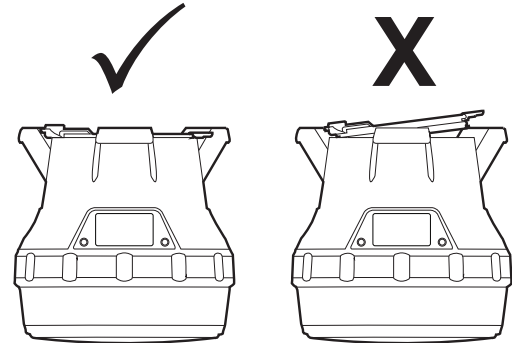

5. While ensuring that the Bottom Cover stays fully seated, turn the Bottom Cover clockwise, while pressing down slightly, until the locking tab lines up with the locking screw.

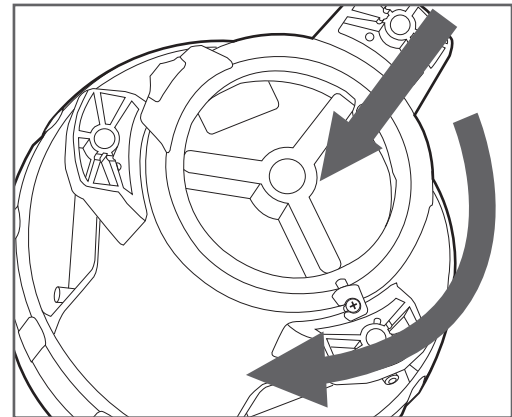

6. (Optional) Tighten the locking screw to lock the cover in the installed position.

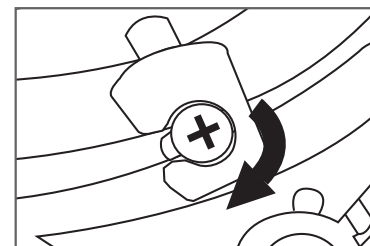

Device Manager Software



Before deploying and installing the OL4, you can connect it to a computer (using a USB cable) and use the Carmanah Device Manager software to:

- Configure the light's parameters
- View detailed information about the light
- Change Day to Night and Night to Day transition settings
- Change the Passcode

Distributors also have access to a suite of advanced features.

For instruction on how to use the Carmanah Device Manager Software, see Appendix A.

On/Off Switch

You can place the OL4 in one of three modes using the **On/Off** switch:

Off Mode

In **Off Mode**, the OL4's main LED will not illuminate at night. During the day the OL4 will continue to charge its Battery Pack through the solar panel.

To place the OL4 in **Off Mode**, move the On/Off switch to the **Off** position. The word "OFF" flashes three times on the display. While in **Off Mode**, the OL4 continues to charge its battery pack when exposed to light, but will not turn on the light when the panel is transitioned from daylight to night..

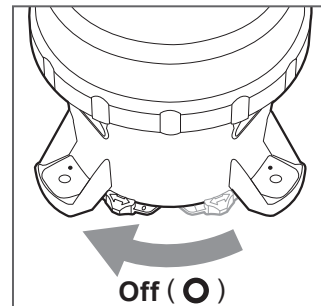

NOTE

If your OL4 is not equipped with the optional On/Off switch, you can set it to **Off Mode** by setting the Flash Code to **000** (page 13) using the OBUI or IR Remote. When the light is set to Off mode with the IR Remote, the light still responds to IR programming. The light does not turn on until the password is reset.

Standard On Mode

In **Standard On Mode**, the OL4's main LED illuminates at dusk (using its programmed Flash Code and effective intensity), remains on all night, and turns off at dawn. The OL4 continues to cycle in this dusk-to-dawn mode as long as the switch remains in the **On** position. When switched to **Standard On Mode**, the display will scroll through a Status Report.

While in **Standard On Mode**, the OL4 continues to charge its batteries when exposed to light.

To place the OL4 in **Standard On Mode**, switch the On/Off switch to the **On** position.

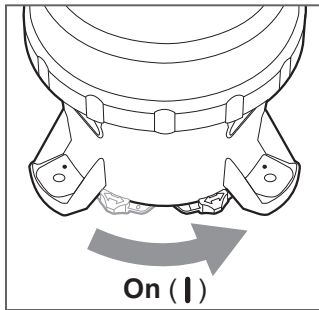

- If you change the OL4 to **Standard On Mode** during the night, the main LED illuminates at the programmed Flash Code and intensity, and remains on until dawn.
- If you change the OL4 to **Standard On Mode** during the day, the OL4's main LED illuminates for 60 seconds at the programmed Flash Code and intensity (to confirm that **Standard On Mode** was accepted), turns off, and then illuminates at dusk.

Fog Mode

With the use of the Carmanah Device Manager software, you can configure the OL4 to operate in **Fog Mode** when the On/Off switch is in the **On** position.

While in **Fog Mode**, whenever the On/Off switch is moved from the **Off** to the **On** position the OL4's main LED immediately illuminates (at its programmed Flash Code and intensity), regardless of ambient light conditions. The OL4 remains illuminated for the rest of that day and night, turns off at dawn the next day, and then operates in **Standard On Mode**.

The difference between **Fog Mode** and **Standard On Mode** is that when the switch is put into the **On** position with the light configured to operate in **Fog Mode**, the OL4 turns on and remains on for the rest of that day.

Infrared Remote Programmer (Optional)

The (optional) Infrared Remote Programmer (IR Remote) allows you to perform certain basic programming functions without having to remove the OL4 from its installed location. The IR Remote allows you to quickly access the following functions without removing the bottom cover:

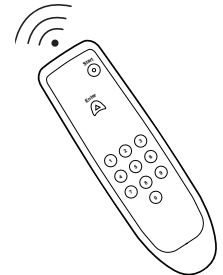

- Check the Battery Pack status
- Change the Flash Code
- Put the OL4 into Ship Mode
- Remove the OL4 from Ship Mode
- Enter **Off** mode

For instructions on how to use the IR Remote, see Appendix B.

NOTE

If you set the OL4 to **Off** mode (Flash Code **000**) using the OBUI, the OL4 still responds to infrared commands.

Infrared commands are ignored if: 1. Carmanah Device Manager is connected. 2. The battery is dead or missing. 3. The OL4 switch is in the **Off** position.

NOTE

The IR remote requires two AAA (1.5 V) batteries.

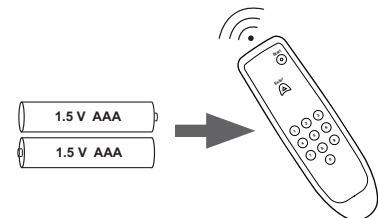

NOTE

Previous versions of the Carmanah IR Remote will work with the OL4.

Battery Pack

Battery Pack Health Status

The OL4 periodically monitors the health of its Battery Pack. There are three Battery Pack health status levels:

Good: the Battery Pack is healthy and charged. A Battery Pack with this health status is ready for deployment.

Charge: the Battery Pack needs to be charged, but is otherwise healthy.

Bad: the Battery Pack is damaged and should be recycled and replaced with a new one.

You can determine the Battery Pack health status using any of the four User Interface methods: the OBUI (via the buttons), the OBUI (via the On/Off switch), the IR Remote, or the Carmanah Device Manager software. The following table indicates how the different User Interface methods report the three levels of Battery Pack health.

Battery Pack Health Status

User Interface	Good	Charge	Bad
OBUI	"good"	"chrg"	"bad"
IR remote (flash response to query)	10 flashes	7 flashes	4 flashes
DeviceManager	"Good"	"Charge"	"Replace"

NOTE

When installing a new battery, press and hold the **Set** button as you insert the battery connector into the OL4 receptacle. Continue to hold the **Set** button until **Zero** is displayed briefly. This resets the OL4's Battery Pack health monitor. Do not hold the Set button while reconnecting a used battery.

NOTE

The most accurate Battery Pack Health Status reading is obtained when the OL4 has been in a dark location and in off mode for at least 24 hours.

Charging the Battery Pack

Solar Charging

The easiest way to charge the Battery Pack is to put the OL4 in a sunny location. The OL4 charges automatically whenever it is exposed to sufficiently intense light. The OL4's charging system continuously monitors solar conditions, and uses a sophisticated Maximum Power Point Tracking (MPPT) algorithm to automatically adjust charging parameters to most efficiently charge the Battery Pack. The OL4 charging system avoids overcharging of the Battery Pack, maximizing its life.

Optional Plug-In Charger

The optional Plug-In Charger allows you to quickly charge the OL4 Battery Pack. The Plug-In Charger automatically charges the Battery Pack. Like the on-board charging system, the Plug-In Charger avoids overcharging the Battery Pack to prolong its life.



Charge the Battery Pack in a well-ventilated, cool spot.



Do not attempt to recharge a bad battery pack with the Optional Plug-In Charger. Damage to the Plug-In Charger may result.

To use the Plug-In Charger:

1. Remove the Bottom Cover.
2. Unplug the Battery Pack connector by pressing down on the latch while gently pulling on the connector body. **Do not pull by the wires.**

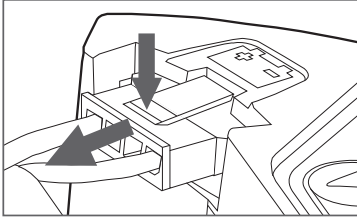

3. Plug the charger connector into the Battery Pack connector (not into the OL4 body).

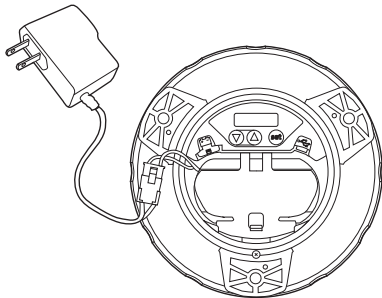

4. Plug the charger into a wall receptacle. Charging a fully discharged Battery Pack with the Plug-In Charger for five hours brings the Battery Pack to a 90% charge.

Charging with an Artificial Light Source

You can also charge the OL4 Battery Pack by placing the OL4 under an artificial light source. However, this method is considerably slower than either solar or plug-in methods.

Keep the following points in mind when charging in this manner:

- Do not use fluorescent lighting to charge the OL4. Using fluorescent lighting does not damage the OL4, but it does not produce enough solar energy to charge the Battery Pack.

- Different light sources produce different charging times, depending on the source wattage and spectral characteristics.
- Do not place the light source too close to the OL4 solar panel, as very high temperatures can damage the light. For example, do not place the OL4 closer than 12" (30 cm) to a 60 Watt light source.

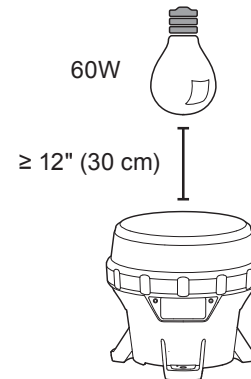

NOTE

Whenever possible, use a fan to blow cool air across the OL4 solar panel when charging under artificial light. This both maximizes the life of the Battery Pack, and accelerates the charging process.

Preserving Battery Pack Health

The OL4 Battery Pack gets charged during the day, and depletes during the night by driving the main LED. Over several years the Battery Pack will degrade and require replacement. Several factors contribute to the OL4 Battery Pack life:

- How sunny the installation location is: choose a sunny, shade-free location.
- How hot the installation or storage location is: choose a cool area, where possible.
- Intensity setting: don't set the light to be brighter than conditions require. A brighter light setting cycles the battery deeper and shortens its lifespan.
- Storage time: the longer an OL4 Battery Pack is stored without being charged, the shorter its life.
- Battery Pack age: over a period of many hundreds of charge/discharge cycles, the Battery Pack chemistry degrades. The OL4 Battery Pack can last over five years, depending on the factors listed above.

Storage Procedures

Please follow these storage procedures to maximize the OL4 Battery Pack life:

- Prior to storage, put the OL4 into Off Mode (pg. 18), Ship Mode (pg. 57), or disconnect the Battery Pack (pg. 22).
- Store in a cool place.
- Follow the recharge interval recommendations presented in the following table:

Battery storage and recharge intervals

Storage Temperature		Recharge Interval (months)
°C	°F	
≤ 20	≤ 68	9
25	77	6
30	86	4
35	95	2.5
40	104	1.5
≥ 45	≥ 113	1

Do not store the OL4 for long periods without charging the Battery Pack, either with the optional Plug-In Charger (pg. 20), or by placing it in the sun until the reported Battery Pack health is Good. The amount of time it takes to charge in the sun depends on the installation location, weather, and the initial Battery Pack state of health.

Replacing the Battery Pack

At the end of the OL4 Battery Pack's life, you can remove it and replace it. Always recycle used Battery Packs appropriately.

To remove the Battery Pack:

1. Remove the Bottom Cover (pg. 11).
2. Unplug the Battery Pack connector by pressing down on the latch while gently pulling on the connector body. **Do not pull by the wires.**

NOTE

Disconnect the USB cable and Battery Pack connector before removing the Battery Pack.

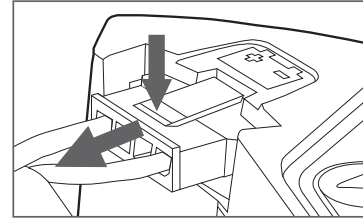

3. Unhook the Battery Pack strap from the tab in the chassis, and pull the Battery Pack strap out of the way.

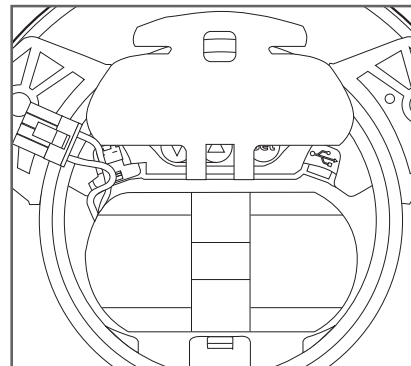
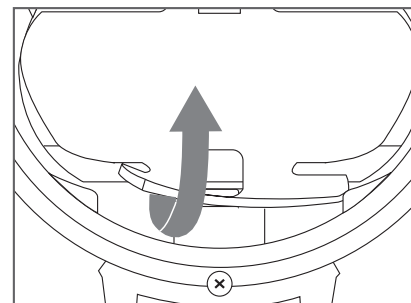
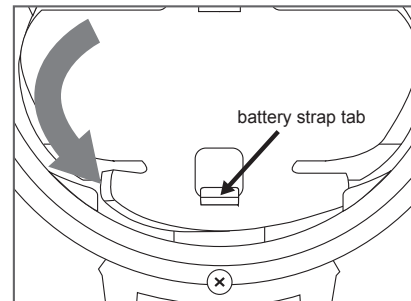

4. Insert a finger under the Battery Pack ribbon, and lift the Battery Pack out. Be careful not to pinch any wires between the Battery Pack and the housing body.

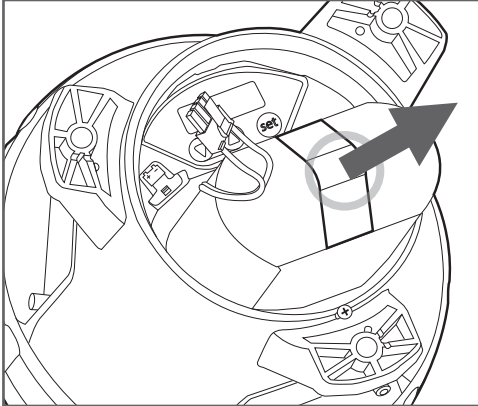

To install the Battery Pack, follow the steps above in reverse. Before mating the new Battery Pack connector with the OL4 receptacle, press and hold the **Set** button until **Zero** shows briefly on the display. Take care not to pinch any of the wires when seating the Bottom Cover after inserting a new Battery Pack.

NOTE

When installing a new battery, press and hold the **Set** button as you insert the battery connector into the OL4 receptacle. Continue to hold the **Set** button until **Zero** is displayed briefly. This resets the OL4's Battery Pack health monitor. Do not hold the Set button while reconnecting a used battery.

Maintenance

After installation, the OL4 requires no day-to-day maintenance.

On occasion, you may want to inspect the OL4 to ensure the solar panel has not been fouled. During typical operation, you can leave the OL4 alone until it stops functioning. At this point you may have to replace the existing Battery Pack with a new Battery Pack. For instructions on how to remove and replace the Battery Pack, refer to page 22 of this manual. For Battery Pack part numbers and ordering instructions, refer to Appendix C.

You can clean an OL4 with water and a mild detergent. Avoid any harsh detergents. Pressure washing is a convenient way to clean the OL4, and won't cause damage to the light. Follow the guidelines below to pressure wash the OL4:

- Use a 40° nozzle (white)
- Do not exceed 2900psi
- Keep the nozzle at least 6" (15cm) away from the OL4

Recycling

The Battery Pack

When the OL4 reports the Battery Pack's Health as "bad", the Battery Pack should be removed from the OL4 and replaced with a new Battery Pack. Consult carmanah.com or your Carmanah distributor.

Bring the used Battery Pack to a lead-acid battery collection, or appropriate recycling facility. DO NOT dispose of it in the garbage.



Pb

Shipping

Ship Mode

Before shipping an OL4, you should place it in **Ship Mode** using either the IR Remote or the Carmanah Device Manager software.

- Refer to page 57 for instructions on how to place the OL4 into **Ship Mode** using the IR Remote.
- Refer to Appendix A for instructions on how to place the OL4 in **Ship Mode** using the Carmanah Device Manager software.

After the OL4 enters **Ship Mode**, place it into the box in which it is being stored or shipped, and close the lid to ensure it stays in darkness. The main LED remains off until the OL4 is removed from the box and senses a day-to-night transition. It then continues to operate in **Standard On Mode**.

Appendix A: Carmanah Device Manager Software

The OL4 uses the Carmanah Device Manager (650DM) software to:

- Configure the OL4's parameters.
- View detailed information about the light.
- Change Day to Night and Night to Day transition settings.
- Change the passcode(s)

Distributors also have access to a suite of advanced features.

System Requirements

To run the software, your computer must meet the following requirements:

Hardware Requirements

- Pentium II processor, or higher
- 250 MB free disk space (if .Net framework not yet installed on the computer)
- 50 MB free disk space (if .Net framework already installed)
- 32 bit colour, 1024 X 768 minimum resolution
- One available USB port
- One USB cable

Software Requirements

- Windows XP, Service Pack 2 or 3

NOTE

If your computer already has the .Net framework installed, the Carmanah Device Manager will install in a few seconds. If the .Net framework is not installed, installation will take between 5 and 10 minutes.

Installation Procedure

If your system meets the system requirements outlined in the previous section, install the Carmanah Device Manager by following the steps below.

1. Insert the CD into your disc drive. The *Device Manager* installation screen appears.



2. Click **Next**. The *License Agreement* appears.

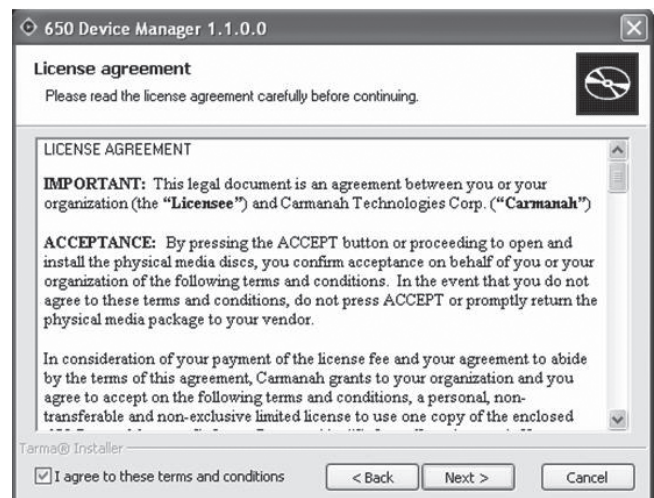

3. After reading the *License Agreement*, check the checkbox in the bottom left corner of the window and click **Next**. The *Installation options* window appears.

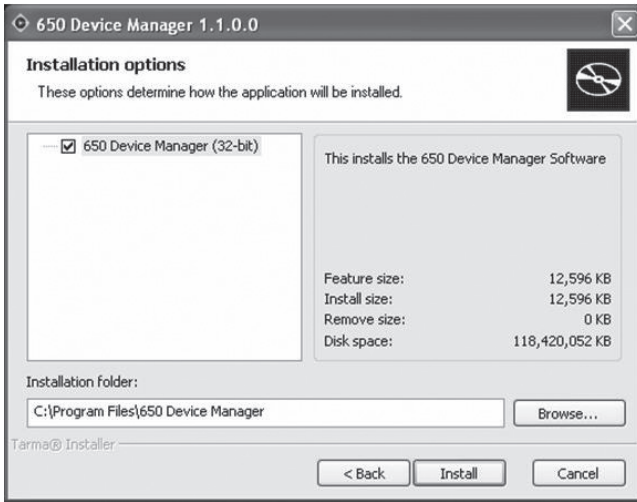

- If you approve of the default installation folder, click **Install**. If you prefer to install Carmanah Device Manager in another folder, click **Browse**, navigate to the correct folder, then click **Install**.

NOTE

If your computer doesn't have the .Net framework installed, it will be installed now. This process can take between 5 and 10 minutes; please wait while it installs.

After the installation is complete, the *Installation completed* window appears.

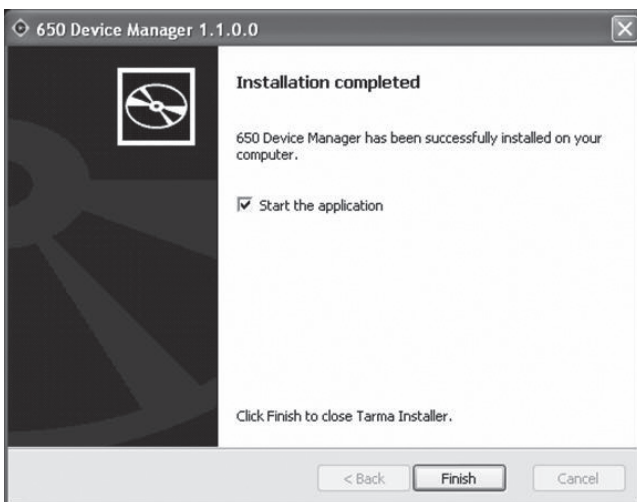

Congratulations, you have successfully completed your Carmanah Device Manager installation.

NOTE

To remove the Carmanah Device Manager from your computer, press the **Start** button, select **Set Program Access and Defaults**, and choose **Change or Remove Programs**. Select **650 Device Manager** from the list of programs, and click the **Remove** button.

NOTE

Before installing a new version of the Carmanah Device Manager, first remove the previous version (if installed).

Removing the Bottom Cover

Before you can connect the USB cable to the light, you must remove the light's Bottom Cover. To do this:

- Turn the light upside down and place it on a soft cloth (to avoid scratching the housing).

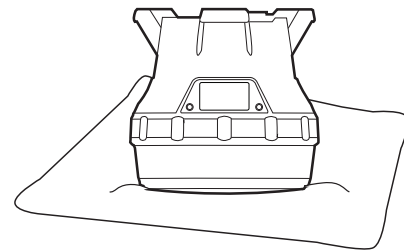

- Locate and turn the locking screw counter-clockwise to loosen it (you do not have to remove the locking screw).

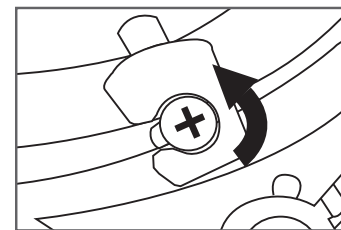

- Secure the light so it won't move, and then firmly twist the Bottom Cover counter-clockwise until it stops.

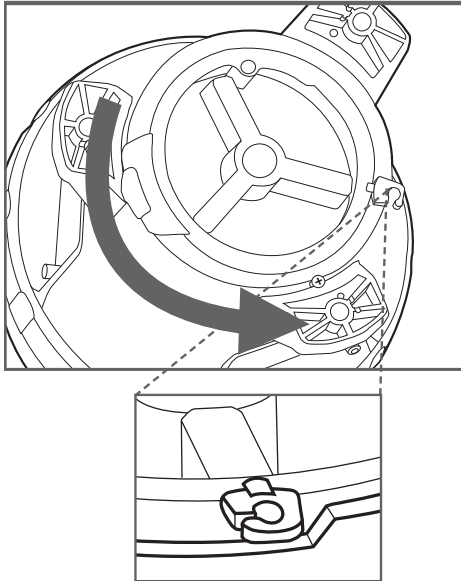

4. Lift the cover out using the protruding locking tab. You can now access the USB connector port (for using the Carmanah Device Manager software).

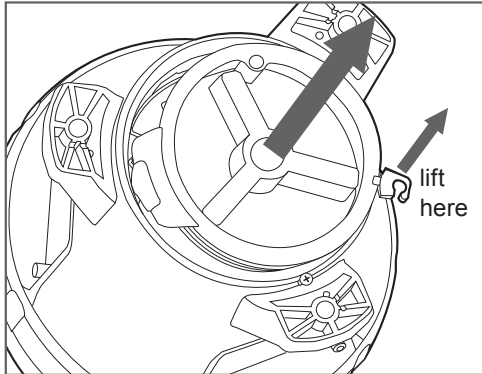

5. Using the USB cable provided with your Carmanah Device Manager software, connect the larger end to an available USB connector in your computer. Connect the other smaller end to the USB connector inside the OL4.

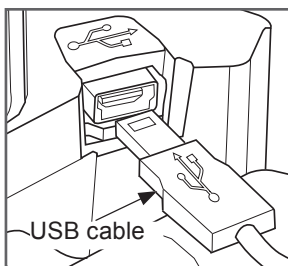

Logging In

To login to the software:

1. From either the **Start/Program** menu or your Windows Desktop, click the **Carmanah Device Manager icon**. The *Device Manager Status* screen appears.



2. From the *Device Manager Status* screen, click **Login Here**.

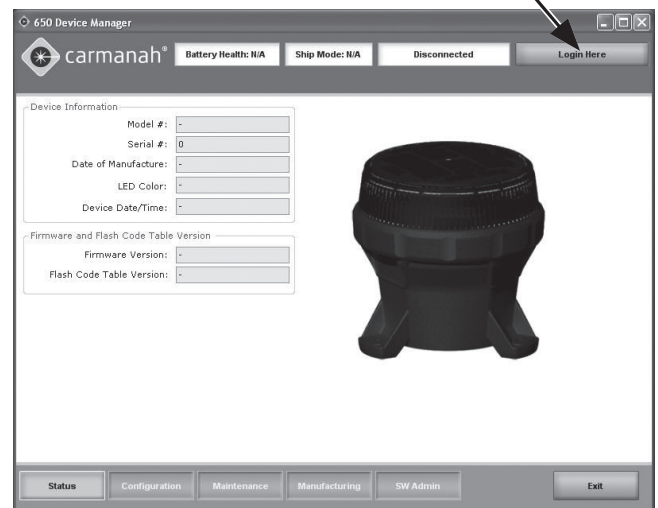

The *Login* dialog box appears.

NOTE

You can disconnect your USB cable from a light and reconnect to another light without logging out of the software. It will take a few seconds to connect to the new light.

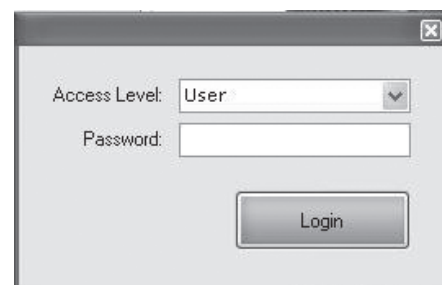

- In the *Access Level* field, select **User** from the drop down menu. The default User Access Level password is **1Cmh2**

NOTE

You will only have access to the software functions associated with the Access Level at which you log in. (Distributor and Manufacturing Access Levels are able to modify a wider range of light parameters.)

- Enter the **Password** and click **Login**.

If you've connected an OL4 light to your computer using a USB cable, then after a short pause, the software connects to the light, and a coloured picture of the OL4 on the main screen replaces the darkened picture. The picture that appears matches the LED colour of the OL4.

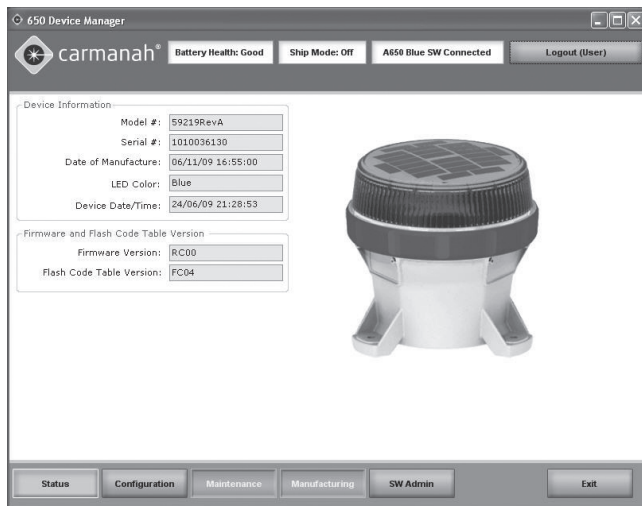

Once you successfully login, several of the buttons in the *Bottom Bar* become active. Inactive buttons display with white text.

User Functions

The procedures in the following section are available to all Access Levels (User, Distributor and Manufacturing).



The following section describes the various parts of the Carmanah Device Manager screen:

TOP BAR	<p>The <i>Top Bar</i> is the blue area at the top of the window. It always contains the following information boxes:</p> <p>Battery Health: This gives you a quick snapshot of the battery's current state of health:</p> <ul style="list-style-type: none">Good: the Battery Pack is healthy, and charged. A Battery Pack in this state is ready for deployment.Charge: the Battery Pack needs to be charged, but is otherwise healthy.Replace: the Battery Pack should be recycled, and replaced with a new one.Ship Mode: This indicates if the light is currently in Ship Mode (Ship Mode: On). <p>Disconnected/(Model Name) Connected: This indicates the software connection status. If your computer is not connected to a light, it displays Disconnected. When connected to a light, it displays the light's model name.</p> <p>Login Here/Logout (Access Level): Click this button to log out of the Carmanah Device Manager. The name in brackets indicates the access level of the user currently logged in to the device (User, Distributor, or Manufacturing).</p>
FUNCTION PAGE	<p>The centre area of the screen contains the <i>Function Page</i> information. Different content appears in this area, depending on the button you select from the Bottom Bar.</p>
BOTTOM BAR	<p>The <i>Bottom Bar</i> contains buttons that allow you to access the software's various function pages. As a User, you can access the following pages:</p> <p>Status: (the default page when you log in): This page contains basic status information about the OL4 device that is currently plugged into the computer.</p> <p>Configuration: This page displays the attached light's current configuration, and allows you to change various settings (for example, Flash Code and Effective Intensity).</p> <p>SW Admin: This page has two tabs: the <i>Connection Tab</i> (which allows you to view your current Connection Status, Com Port address, and software version number), and the <i>Security Tab</i> (which allows you to change passwords).</p> <p>Exit: Click Exit to end your current session and close the software.</p>

Checking the Light's Status

After logging in to the software as a User, the *Device Manager Status Page* appears. This section describes the various functions of the *Status Page*.

NOTE

The *Status Button* highlights in yellow in the *Bottom Bar*.

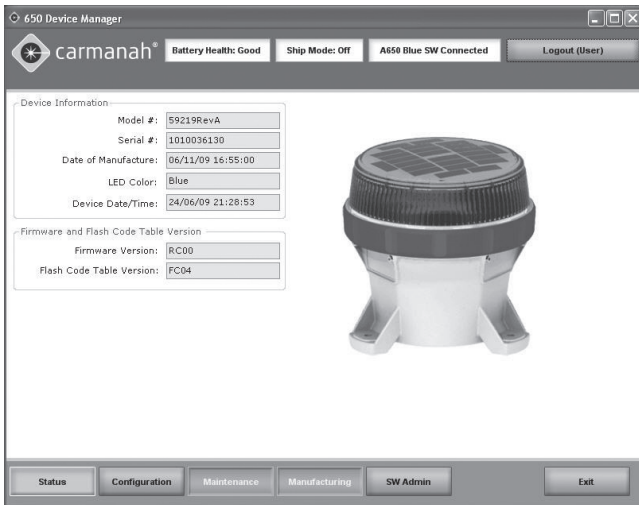

Status Page

After logging in to the software, the Status Page appears. The following are the various functions of the Status Page.

AREA NAME	DESCRIPTION
Device Information Area	Model #: the light's model number.
	Serial #: the light's serial number.
The Device Information Area contains:	Date of Manufacture: the date the light was manufactured.
	LED Colour: the colour of the LED in the light.
	Device Date/Time: the date and time currently programmed on the light.
Firmware and Flash Code Table Version	Firmware Version: the current firmware version loaded onto the light.
The Firmware and Flash Code Table Version area contains:	Flash Code Table Version: the version of the Flash Code Table that is currently loaded on the light.

Configuration Page

The *Configuration Page* displays the light's current settings, and allows you to modify some of these settings. The columns under the "Setting" headings (the *Setting Columns*, shown in solid-line boxes below) indicate the software's current setpoints. The columns under the "Device" headings (the *Device Columns*, shown in dashed-line boxes below) show the connected light's settings.

The general method for changing a setting involves changing the software setpoint(s) in the *Setting Columns* and then sending the setting(s) to the light using the **Send Settings to Device** button.

NOTE

A User cannot edit the *Geography* or the *Set Device Access* areas.

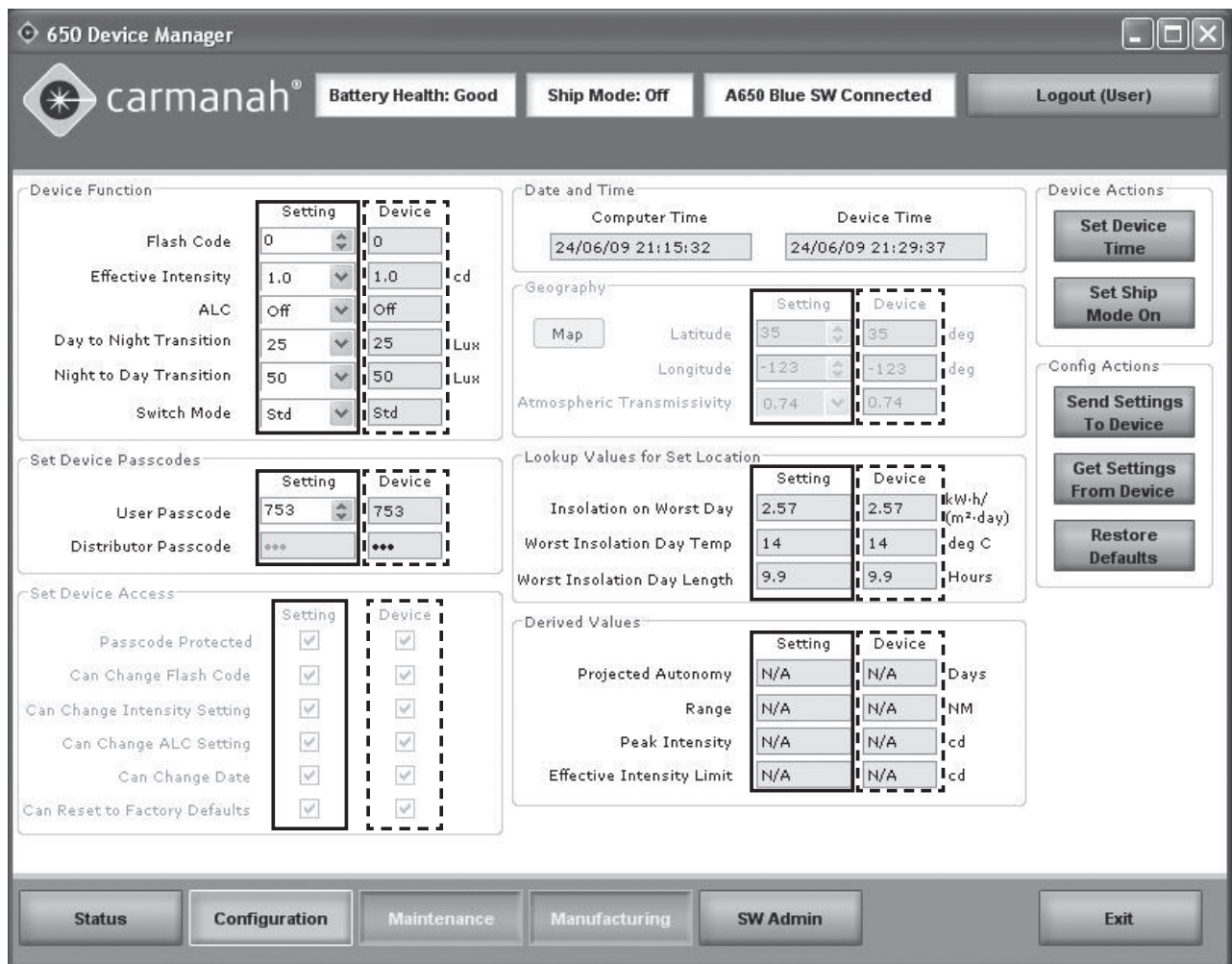

650 Device Manager

carmanah® Battery Health: Good Ship Mode: Off A650 Blue SW Connected Logout (User)

Device Function

	Setting	Device	
Flash Code	0	0	
Effective Intensity	1.0	1.0	cd
ALC	Off	Off	
Day to Night Transition	25	25	Lux
Night to Day Transition	50	50	Lux
Switch Mode	Std	Std	

Date and Time

Computer Time: 24/06/09 21:15:32 Device Time: 24/06/09 21:29:37

Geography

Map Latitude: 35 deg Longitude: -123 deg Atmospheric Transmissivity: 0.74

Set Device Passcodes

	Setting	Device
User Passcode	753	753
Distributor Passcode	***	***

Set Device Access

	Setting	Device
Passcode Protected	<input checked="" type="checkbox"/>	<input checked="" type="checkbox"/>
Can Change Flash Code	<input checked="" type="checkbox"/>	<input checked="" type="checkbox"/>
Can Change Intensity Setting	<input checked="" type="checkbox"/>	<input checked="" type="checkbox"/>
Can Change ALC Setting	<input checked="" type="checkbox"/>	<input checked="" type="checkbox"/>
Can Change Date	<input checked="" type="checkbox"/>	<input checked="" type="checkbox"/>
Can Reset to Factory Defaults	<input checked="" type="checkbox"/>	<input checked="" type="checkbox"/>

Lookup Values for Set Location

	Setting	Device	
Insolation on Worst Day	2.57	2.57	kWh/(m ² .day)
Worst Insolation Day Temp	14	14	deg C
Worst Insolation Day Length	9.9	9.9	Hours

Derived Values

	Setting	Device	
Projected Autonomy	N/A	N/A	Days
Range	N/A	N/A	NM
Peak Intensity	N/A	N/A	cd
Effective Intensity Limit	N/A	N/A	cd

Device Actions: Set Device Time, Set Ship Mode On

Config Actions: Send Settings To Device, Get Settings From Device, Restore Defaults

Status Configuration Maintenance Manufacturing SW Admin Exit

The following fields are available on the *Configuration* Page:

AREA NAME	DESCRIPTION
Device Function	<p>Flash Code: Either type in the correct Flash Code, or click the up and down arrows to select the correct Flash Code. Refer to Appendix F for more information.</p> <p>Effective Intensity: Either type in the desired Effective Intensity setting, or click the down arrow and select the Effective Intensity setting from the drop-down menu. For more information about Effective Intensity, see the Derived Values section of this table, below.</p> <p>ALC: Click the down arrow and select On (to enable ALC) or Off (to disable ALC). For more information about ALC, refer to page 14 of the User Manual.</p> <p>Day to Night Transition Level: Either type in the correct Day to Night Transition Level (D2N) setting, or click the down arrow to select the correct D2N Transition Level setting. For more information about the D2N Transition Level, refer to the table on page 38.</p> <p>Night to Day Transition Level: Either type in the correct Night to Day Transition Level (N2D) setting, or click the down arrow to select the correct N2D Transition Level setting. For more information about the N2D Transition Level, refer to the table on page 38.</p> <p>Switch Mode: If the light is equipped with the optional external switch, you can change the Switch Mode between Standard Mode (Std) and Fog Mode (Fog). For more information about the Switch Mode, refer to the table on page 39.</p>
Set Device Passcodes	<p>User Passcode: This is the passcode that users enter when logging into a light using the On-Board User Interface (OBUI). You can edit the passcode by typing in the desired setting, or using the up/down arrows.</p> <p>Distributor Passcode: This field is only editable by someone logged in at the Distributor or Manufacturing Access Level.</p>
Date and Time	<p>Computer Time: This is the current date and time, synchronized with the computer on which the software is installed.</p> <p>Device Time: This is the time currently configured on the light. To synchronize the time of a connected light to the computer time, click Set Device Time.</p>
Derived Values	<p>Projected Autonomy: This indicates the estimated number of days of dusk-to-dawn operation the light can sustain without any solar energy being gathered by the solar panel. The Projected Autonomy changes to reflect any changes to the Flash Code, Effective Intensity, and Transition light level settings.</p> <p>Range: This is the range of the light, in nautical miles, when programmed with the current settings. It is calculated using the methods outlined in IALA E-122, Section 1.5.</p> <p>Peak Intensity: This is the intensity of the light, in candela, when the LED is on. The Peak Intensity value, unlike the Effective Intensity value, does not take into account the programmed Flash Code: it is the instantaneous intensity of the light during the “on” portion of the Flash Code.</p>

AREA NAME	DESCRIPTION
	<p>Effective Intensity Limit: This is the maximum Effective Intensity which can be programmed without exceeding the available solar energy. This prevents the light from being deployed at a setting which isn't sustainable. Factors that influence the Effective Intensity Limit include: Flash Code, Day to Night and Night to Day Transition, Latitude and Longitude, and Atmospheric Transmissivity. The Effective Intensity of a flashing light is the intensity that a steady-on light must have to appear equivalently bright. It is calculated using the method of Schmidt-Clausen, as per IALA E-122, Section 1.4.</p> <p>NOTE The Peak Intensity and Effective Intensity values correspond to the intensity of the beam at 3° above the horizon.</p>
Device Actions	<p>Set Device Time: Click this to synchronize the computer time with the light time.</p> <p>Set Ship Mode On: Click this to put the light into Ship Mode (Set Ship Mode On), or take the light out of Ship Mode (Set Ship Mode Off). For more information on Ship Mode, refer to the Ship Mode section of this Appendix.</p>
Config Actions	<p>Send Settings to Device: This sends the settings currently shown in the Setting Columns to the light. Note that this button becomes inactive when the values in the Setting Columns would require more solar energy than is available at the programmed location (Latitude and Longitude). When this occurs, red exclamation points highlight the settings that are contributing to the energy deficit. If you put your mouse pointer over the exclamation point, a message indicates the problem.</p> <p>Get Settings from Device: Click this to retrieve the light's current settings and copy them into the Setting column. Note that when the software connects to a light, it does this automatically.</p> <p>Restore Defaults: This restores the settings that were last programmed at the Distributor or Manufacturing Access Level. If the light's settings have only been changed at the User Access Level, the settings return to what they were when you first received the light.</p>

SW Admin Page

The SW Admin (Software Administration) page has two tabs that allow you to view connection and software version information (*Connection tab*) and to set login password(s) (*Security tab*).

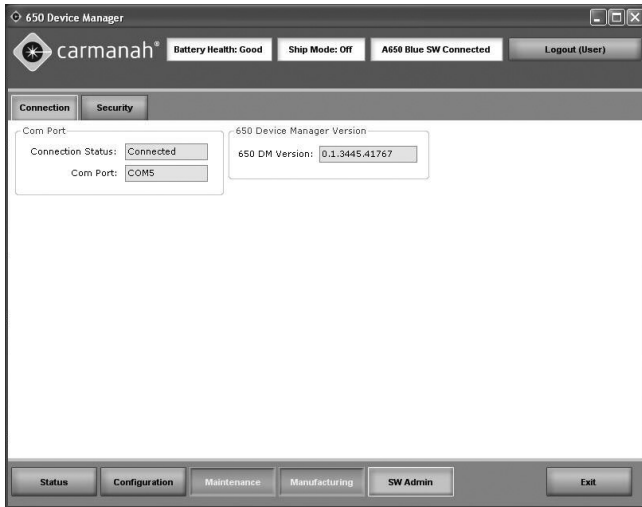

AREA NAME	DESCRIPTION
<i>Connection Tab:</i>	
Connection Status	The <i>Connection Status</i> field indicates if you are currently connected or not connected to a light.
Com Port	The <i>Com Port</i> field displays the current communications port through which the light is connected to the software.
<i>Connection Tab:</i>	
650DM Version	This field displays the version of the software currently installed on the computer.

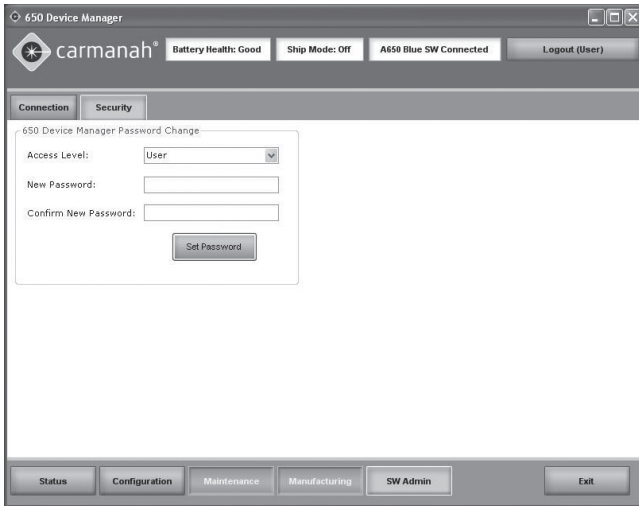

AREA NAME	DESCRIPTION
-----------	-------------

Security Tab:

Password Change

After clicking the *Security Tab*, the *Device Manager Password Change* area appears. This allows you to change the password that is entered when you login to the Carmanah Device Manager software.

To set a new password, select the appropriate Access Level from the Access Level drop-down menu, enter the new password in the *Password* field, and click **Set Password**.

NOTE

If you are logged in as a User, you will only see the Access Level "User". If you are signed in as a Distributor, you will see both Distributor and User.

Initial Configuration

After receiving your light from a Carmanah Distributor, most of the light's settings should already be configured. If you want to further customize these settings, follow the associated procedure.

SETTING	DEFINITION	PROCEDURE
Flash Code	The Flash Code controls the flash pattern the light emits during operation. Select the appropriate Flash Code from the Flash Code Table (see Appendix F) and enter the code in this field.	Either type in the correct Flash Code, or click the up and down arrows to select the desired Flash Code.
Effective Intensity	The Effective Intensity setting controls the light's brightness. A higher Effective Intensity setting allows the light to be seen from farther away, but also uses up more battery power and requires more solar energy. The Effective Intensity setting is measured in candela, and takes into account the programmed Flash Code (using the method of Schmidt-Clausen as per IALA E-122, Section 1.4). The Effective Intensity value is measured at 3° above the horizon.	Either type in the correct Effective Intensity setting, or click the down arrow and select the correct Effective Intensity setting.
ALC (Automatic Light Control)	<p>When ALC is enabled, the light monitors the battery pack's state of charge and reduces the intensity level if the light is not receiving sufficient solar charging to maintain the battery pack. When the battery pack recovers, ALC automatically resumes operation at the programmed Effective Intensity.</p> <p>If the light's latitude and longitude are set correctly, ALC reduces the Effective Intensity setting for the light only under unusually poor solar conditions.</p>	Click the down arrow and select On (to enable ALC) or Off (to disable ALC).
Day to Night Transition Level	As the sun goes down in the evening, the ambient brightness level goes down with it. The Day to Night Transition Level (D2N) is the ambient light level (measured in lux) at which the light's beam will turn on in the evening. A lower D2N results in the light turning on later, conserving battery power.	Click the down arrow and select the correct Day to Night Transition Level setting.
Night to Day Transition Level	As the sun rises, the ambient light level goes up. The Night to Day Transition Level (N2D) is the ambient light level (in lux) at which the light's beam turns off in the morning. A lower N2D results in the light turning off earlier, conserving battery power.	Click the down arrow and select the correct Night to Day Transition Level setting.

NOTE

The N2D setting must be at least 25 lux greater than the D2N setting

SETTING	DEFINITION	PROCEDURE
Switch Mode	<p>For lights equipped with the optional external switch, two Switch Modes are available. These modes control the behaviour of the light when switched on during the day using the external switch:</p> <p>Standard Mode (Std): If the light is switched on during the day in this mode, the light will turn on for a minute or two to demonstrate the programmed flash code and intensity, and then extinguish until the programmed D2N light level is sensed.</p> <p>Fog Mode (Fog): When switched on during the day in Fog Mode, the light will turn on, and remain on for the rest of that day and the following night. It will extinguish the next morning, when the N2D light level is sensed. It will then return to normal dusk-until-dawn behaviour. Fog Mode can be used to force the light on during the day.</p>	Click the down arrow and select Std (for Standard Mode) or Fog (for Fog Mode).
User Passcode	The User Passcode is the 3-digit number that you must enter on the OBUI to modify the light's settings (unless the light is configured so as not to require passcode entry to edit settings).	Either type in the desired User Passcode, or click (and hold, if desired) the up/down arrows to select your preferred User Passcode.
Set Device Time	<p>This sets the internal clock on your light to be the same as the time on your computer.</p> <div style="border: 1px solid black; padding: 2px; display: inline-block; margin-bottom: 5px;">NOTE</div> <p>The OL4 is equipped with an algorithm that uses daily transition events to periodically correct for its clock drifting over time. It's not critical that the internal light clock and computer times be identical; the internal light clock exists only for datalogging purposes.</p>	Click this button to synchronize the time on your light to the time on your computer. After pressing the button, the times displayed in the <i>Date and Time</i> area should be identical.
Set Ship Mode On / Set Ship Mode Off	This allows you to set the light to Ship Mode. Ship Mode prevents the light's beam from turning on until it detects a Night to Day transition event, at which point the light exits Ship Mode and resumes normal operation. Use Ship Mode whenever you store the light somewhere where it remains consistently dark (like inside a closed box). If you don't use Ship Mode prior to placing a light in a consistently dark location, the light's beam will turn on for ~24h, at which time it will automatically enter Ship Mode. To conserve battery power, however, it's preferable to put the light into Ship Mode prior to dark storage.	<p>Click this button to enter your light into Ship Mode. Click the button again to turn Ship Mode off.</p> <p>To confirm Ship Mode, look at the Top Bar.</p>

SETTING	DEFINITION	PROCEDURE
Send Settings To Device	<p>Click this to send the settings currently shown in the <i>Setting</i> columns to the light.</p> <p>Note that this button becomes inactive when the values in the <i>Setting</i> columns would require more solar energy than is available at the programmed location (latitude and longitude). When this occurs, red exclamation points highlight the settings that are contributing to the energy deficit. If you put your mouse pointer over the exclamation point, a message indicates the problem.</p>	<p>With the light plugged into your computer, click the button to send the values in the <i>Setting</i> column on the <i>Configuration</i> page to the light.</p>
Get Settings From Device	<p>Click this to retrieve the light's current settings and copy them into the <i>Setting</i> column. Note that when software connects to a light, it does this automatically.</p> <p>Use the Get Settings From Device button if you have modified the values in the <i>Setting</i> columns of the <i>Configuration</i> page, but don't want to send the settings to the light.</p>	<p>With the light plugged into your computer, click Get Settings From Device to populate the <i>Setting</i> columns' values with those programmed on the light.</p>
Restore Defaults	<p>This restores the settings that were last programmed at the Distributor or Manufacturing Access Level. If the light's settings have only been changed at the User Access Level, the settings will return to what they were when you first received the light.</p>	<p>With the light plugged into your computer, click Restore Defaults to populate the <i>Setting</i> columns' values with those originally programmed on the light.</p>

User Tasks

Restoring the Default Configuration

If you are unsure of your light's current configuration, or if you accidentally change a setting while customizing your light's settings, you can restore the light to its default configuration. The light's default configuration is the settings that were last programmed by either your Distributor, or Carmanah Manufacturing.

Restoring the default configuration changes the following settings (if they're different from the current values): Flash Code, Effective Intensity, Automatic Light Control, Day to Night Transition, Night to Day Transition, Switch Mode, and User Passcode.

NOTE

Latitude/Longitude, Transmissivity, and Distributor Passcodes won't change.

To restore the default configuration:

1. Remove the light's Bottom Cover and plug the USB cable into the USB port.
2. Connect the other end of the USB cable to an empty USB port on your computer.
3. Open 650DM on your computer. It may take a moment to find and connect to the light.
4. Click **Configuration** on the Bottom Bar. The Configuration screen appears.
5. Click **Restore Defaults** (on the right side of the screen). The light's current settings are replaced with the settings last programmed by your Distributor or Carmanah Manufacturing.

Using the Derived Values

Derived Values are calculated based on the settings you select for your light. The values described in the following table are calculated from the following settings: Flash Code, Effective Intensity, Day to Night Transition, Night to Day Transition, the Latitude and Longitude, and Transmissivity.

If you change any of these settings, the software calculates the effects of your changes on the light, and displays the results in the Derived Values area of the Configuration Page.

Note that until you use the **Send Settings to Device** button, the values in the *Device* columns remain unchanged. This allows you to compare the light's current derived values with those resulting from the settings currently entered in the *Setting* columns in the *Device Function* area.

VALUE	DEFINITION	HOW THEY CHANGE
Projected Autonomy	This indicates the estimated number of days of dusk-to-dawn operation the light can sustain without any solar energy being gathered by the solar panel.	<p>If you change any of the settings that affect the light's power consumption, the Projected Autonomy will automatically update to reflect that change.</p> <p>If a settings change results in the light using less power, then the Projected Autonomy value increases. If the change requires more power from the light, then the Projected Autonomy value decreases.</p>
Range	This is the visible range of the light, in nautical miles, when programmed with the current settings. It is calculated using the methods outlined in IALA E-122, Section 1.5.	<p>If you change the <i>Effective Intensity</i> setting, the Range value updates accordingly.</p> <p>If you've increased the <i>Effective Intensity</i> setting, the Range value will also increase. If you lower the Effective Intensity setting, the Range value decreases.</p>
Peak Intensity	<p>This is the intensity (brightness) of the beam when the LED is on. This value is expressed in candela.</p> <p>The Peak Intensity gives the intensity of the beam 3° above the horizon.</p>	<p>If you change the <i>Effective Intensity</i> setting, the Peak Intensity value updates accordingly.</p> <p>If you've increased the <i>Effective Intensity</i> setting, the Peak Intensity value also increases. If you lower the Effective Intensity setting, the Peak Intensity value decreases.</p>
Effective Intensity Limit	This is the maximum Effective Intensity setting that can be programmed to the light without exceeding the available solar energy. This value changes with Flash Code, D2N and N2D Transition settings, and the Geography settings (Latitude, Longitude and Atmospheric Transmissivity; set by your Distributor or Carmanah Manufacturing).	<p>If you change the <i>Flash Code</i> or <i>Transition</i> settings, the Effective Intensity Limit value updates to reflect that change.</p> <p>If a settings change results in the light using less power, then the Effective Intensity Limit value increases. If the change requires more power from the light, then the Effective Intensity Limit value decreases.</p>

Entering/Exiting Ship Mode

Ship Mode prevents the light's beam from turning on until it detects a Night to Day transition event, at which point the light exits Ship Mode and resumes normal operation. Use Ship Mode whenever you store the light somewhere where it remains consistently dark (like inside a closed box). If you don't use Ship Mode prior to placing a light in a consistently dark location, the light's beam will turn on for ~24h, at which time it will automatically enter Ship Mode. To conserve battery power, however, it's preferable to put the light into Ship Mode prior to dark storage.

NOTE

After you put a light into Ship Mode, immediately place the light into a dark, sealed storage box (to prevent it from experiencing a Night to Day transition and returning to normal operation).

To put a light into Ship Mode (turning Ship Mode On):

1. Remove the light's Bottom Cover and plug the USB cable into the USB port.
2. Connect the other end of the USB cable to an empty USB port on your computer.
3. Open 650DM on your computer. It may take a moment to find and connect to the light.
4. Click **Configuration** on the Bottom Bar. The *Configuration* screen appears.
5. Click **Set Ship Mode On** (on the right side of the screen). To confirm that the light is in Ship Mode, **Ship Mode: On** appears in the middle of the top bar

To take a light out of Ship Mode (turn Ship Mode Off):

There are three ways to restore a light from Ship Mode. You can take the light out of the storage box and place it in bright light for a few moments, followed by darkness; you can use the infrared programmer; or you can use the software as follows:

1. Remove the light's Bottom Cover and plug the USB cable into the USB port.
2. Connect the other end of the USB cable to an empty USB port on your computer.
3. Open 650DM on your computer. It may take a moment to find and connect to the light.
4. Click **Configuration** on the Bottom Bar. The *Configuration* screen appears.
5. Click **Set Ship Mode Off** (on the right side of the screen). The light exits Ship Mode and resumes normal operation. To confirm that the light is out of Ship Mode, **Ship Mode: Off** appears in the middle of the top bar..

Setting the Time

When a light's battery pack is removed, the light's internal clock stops. When another battery pack is installed, the light sets its internal clock to use the last time recorded in its datalog. This may be quite close to the actual time if the light hasn't gone without power for long, but for a light that remains without a battery pack connected for more than a few hours, the internal clock should be updated using the **Set Device Time** button. To restore the light's clock to reflect the same time as on your computer, use the following procedure.

To set the light's time:

1. Remove the light's Bottom Cover and plug the USB cable into the USB port.
2. Connect the other end of the USB cable to an empty USB port on your computer.
3. Open 650DM on your computer. It may take a moment to find and connect to the light.
4. Click **Configuration** on the Bottom Bar. The *Configuration* screen appears.
5. Click **Set Device Time** (on the right side of the screen). The light's time now matches the time on your computer. To confirm this, you can look at the Date and Time area on the Configuration page. Both the *Computer Time* and *Device Time* fields should match.

Setting the Day to Night Transition Level

The Day to Night Transition Level (D2N) is the ambient brightness (in lux), at which the light will turn on in the evening. A higher value for the D2N Transition Level causes the light to turn on earlier; a lower value causes it to turn on later.

NOTE

Remember that the earlier the light turns on, the more battery power it consumes. Therefore, higher D2N Transition Level settings lower the Effective Intensity Limit and Projected Autonomy slightly.

To set the D2N Transition Level:

1. Remove the light's Bottom Cover and plug the USB cable into the USB port.
2. Connect the other end of the USB cable to an empty USB port on your computer.
3. Open 650DM on your computer. It may take a moment to find and connect to the light.
4. Click **Configuration** on the Bottom Bar. The *Configuration* screen appears.
5. In the *Device Function* area, click the **down arrow** beside the *Day to Night Transition* field, and select the appropriate value. The *Setting* column values for Autonomy and the Effective Intensity Limit (in the *Derived Values* area), change to reflect the effect of the new D2N Transition Level.
6. Click **Send Setting to Device**. The new D2N Transition value is sent to the light. The values for Autonomy and the Effective Intensity Limit, in the *Device* column of the *Derived Values* area, change to reflect the effect of the new D2N Transition Level.

Setting the Night to Day Transition Level

The Night to Day Transition Level (N2D) is the ambient brightness at which the light comes on in the morning (measured in Lux). A higher value for the N2D Transition Level causes the light to turn on later in the morning; a lower value makes it turn on earlier.

NOTE

You cannot program the N2D Transition Level to be lesser value than the D2N Transition Level.

To set the N2D Transition Level:

1. Remove the light's Bottom Cover and plug the USB cable into the USB port.
2. Connect the other end of the USB cable to an empty USB port on your computer.
3. Open 650DM on your computer. It may take a moment to find and connect to the light.
4. Click **Configuration** on the Bottom Bar. The *Configuration* screen appears.
5. In the *Device Function* area, click the **down arrow** beside the *Night to Day Transition* field, and select the appropriate value. The *Setting* column values for Autonomy and the Effective Intensity Limit (in the *Derived Values* area), change to reflect the effect of the new N2D Transition Level. [
6. Click **Send Setting to Device**. The new N2D Transition value is sent to the light. The values for Autonomy and the Effective Intensity Limit, in the *Device* column of the *Derived Values* area, change to reflect the effect of the new N2D Transition Level.

Setting the ALC

When ALC (Automatic Light Control) is enabled, the light monitors the battery pack's state of charge and reduces the Effective Intensity level if the light is not receiving sufficient solar charging to maintain the battery pack's state of charge.

If the light's latitude and longitude are set correctly, ALC reduces the Effective Intensity setting for the light only under unusually poor solar conditions.

To turn ALC off:

1. Remove the light's Bottom Cover and plug the USB cable into the USB port.
2. Connect the other end of the USB cable to an empty USB port on your computer.
3. Open 650DM on your computer. It may take a moment to find and connect to the light.
4. Click **Configuration** on the Bottom Bar. The *Configuration* screen appears.
5. In the *Device Function* area, click the **down arrow** beside the *ALC* field, and select **Off** to disable ALC, or select **On** to enable ALC.
6. Click **Send Settings to Device**. Your setting change is sent to the light.

Changing the Device Manager Password

The Carmanah Device Manager software is delivered with a default login password that allows you to view and edit your light's configuration. Although you can continue to use the default password, you also have the option to change the password to something that is easier to remember or is more secure.

To change your Password:

1. **Open** and **login** to 650DM using your existing password. If this is the first time you are changing the password, use the default User Access Level password **1Cmh2**.
2. Click **SW Admin** on the Bottom Bar. The *Software Administration* screen appears.
3. Click the **Security** tab. The *Security* page appears.
4. In the *Access Level* field, select **User**.
5. In the *New Password* field, enter your new password. Passwords are case-sensitive.
6. In the *Confirm New Password* field, re-type your new password.
7. Click **Set Password**. Your new password is now active.

Understanding the Installation Location Environmental Parameters

The Carmanah Device Manager displays information about the light's installation location based on its programmed geography settings (latitude, longitude, and atmospheric transmissivity). The light uses these parameters (among others) to calculate the light's Effective Intensity Limit. The calculated values appear in the *Lookup Values for Set Location* area.

The parameters that display are:

- **Insolation on Worst Day:** This is a measure of how much sun is available at the light's programmed latitude/longitude during the shortest winter day (this is measured in units of kWh/m²day).
- **Worst Insolation Day Temp:** This is a measure of the lowest expected average winter temperature at the programmed latitude and longitude (in degrees Celsius). This allows for the precise calculation of the efficiency of the following hardware elements, which all vary with temperature: solar panel, battery charger circuitry, battery, LED driver circuitry, and LED.
- **Worst Insolation Day Length:** This is the length of the shortest day of the year at the programmed latitude.

Distributor Functions

The procedures in this section are accessible to anyone with Distributor or Manufacturing access.

Logging In

When logging in as a Distributor, click **Login Here**, select **Distributor** from the *Access Level* drop-down, enter your Distributor password, and click **Login**.

After logging in as a Distributor, you will have access to the *Maintenance* page. Also, other areas of the *Configuration* page become editable.

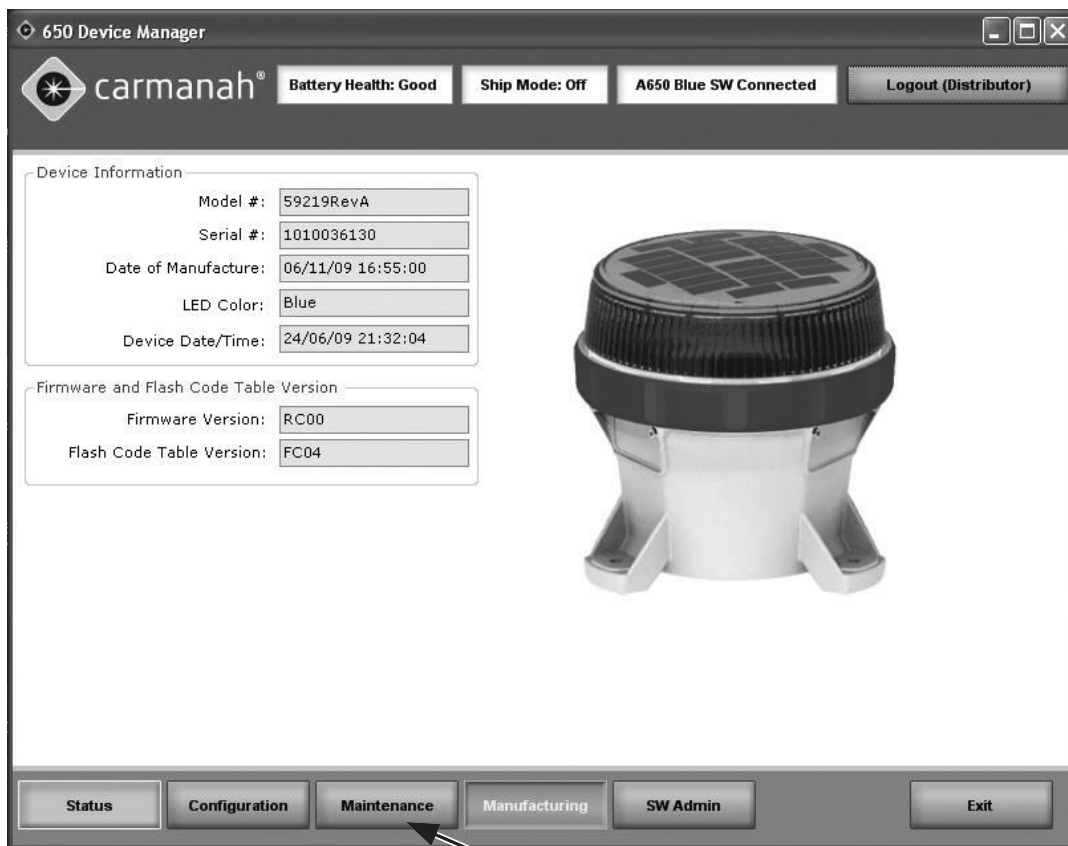

The *Maintenance Page* is available to a Distributor, but not a User.

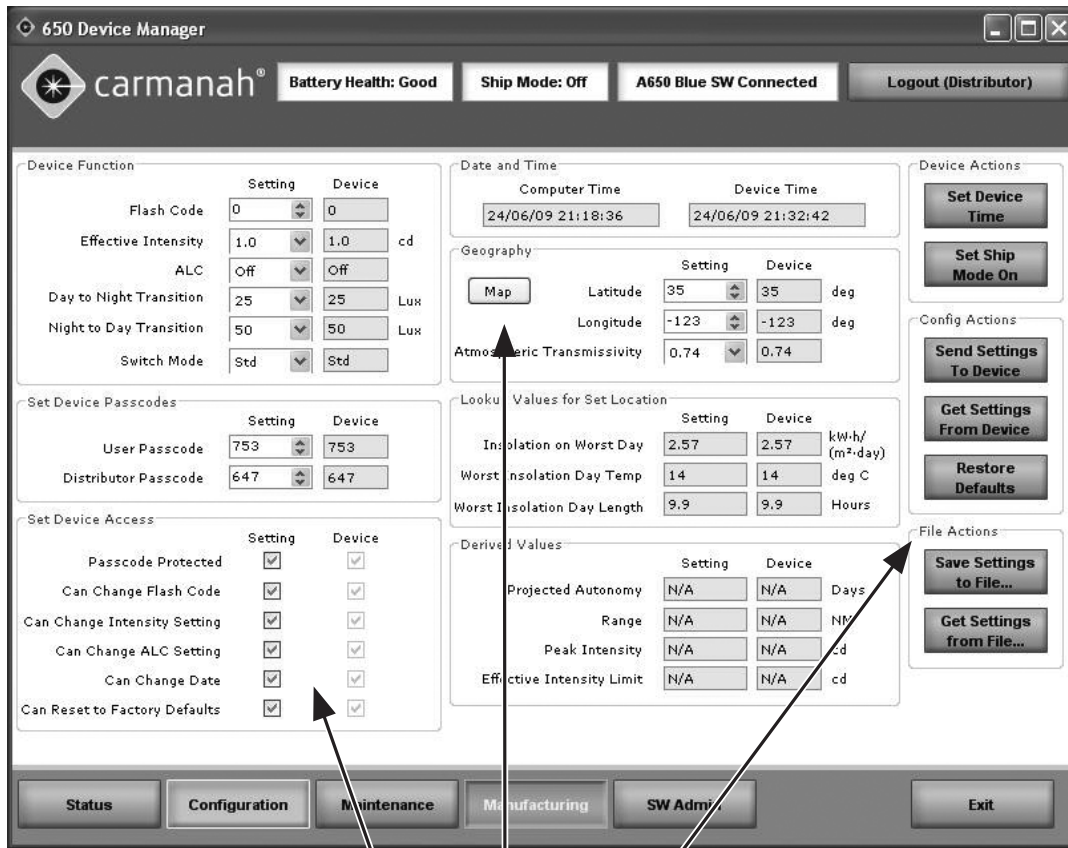

The *Set Device Access*, *Geography*, and *File Actions* areas are available to a Distributor, but not a User. The *Distributor Passcode* field also becomes editable.

Configuring the OL4

The Distributor uses the same procedures as a User to configure an OL4 light. Refer to User section for details on how to configure the light's basic settings.

The following procedures describe the configuration options that are not available to someone with a User Access Level.

Entering the Deployment Location

As a Distributor, when you configure a customer's light, part of the information required is the Deployment Location (where the light will actually be located). This location is expressed in Latitude and Longitude.

Knowing the Deployment Location allows the software to convey to the light how much solar exposure (insolation) it can expect to receive, the lowest average winter temperature for that location, and the shortest length of day at that location. All of these factors play a part in how much energy the light's battery pack can expect to receive to power the light in a reliable manner.

To enter the Deployment Location:

1. Remove the light's Bottom Cover and plug the USB cable into the USB port.
2. Connect the other end of the USB cable to an empty USB port on your computer.
3. Open 650DM on your computer. It may take a moment to find and connect to the light
4. Click **Configuration** on the Bottom Bar. The *Configuration* screen appears.
5. In the *Geography* area, enter the latitude and longitude where the light will be deployed. Alternatively, you can click **Map** and then select the deployment location on the world map that appears. After clicking the light's deployment location, click OK. The location you selected appears in the *Latitude* and *Longitude* fields.
6. To set the *Atmospheric Transmissivity*, click the **down arrow** and select the appropriate value.

Setting the User's Device Access

The *Set Device Access* area allows a Distributor to enable or disable a User's ability to edit specific light configuration parameters.

The administrator at a customer site typically requests that certain settings are made editable at the User level. For example, if the administrator doesn't require the lights to have an access password, or wants to allow a User to change the Flash Code, the Distributor can ensure that the customer's requests are met and become part of the default configuration.

To set a User's Device Access:

1. Remove the light's Bottom Cover and plug the USB cable into the USB port.
2. Connect the other end of the USB cable to an empty USB port on your computer.
3. Open 650DM on your computer. It may take a moment to find and connect to the light.
4. Click **Configuration** on the Bottom Bar. The *Configuration* screen appears.
5. In the *Set Device Access* area, check the checkboxes to enable the associated features, or clear the checkboxes to disable the features.
6. Click **Save Settings to File...** to save the changes as part of the customer's default configuration, or click **Send Settings to Device** to program a connected light with the *Device Access* settings. The checkboxes in the *Device* column indicate the light's current configuration.

Setting	Device
0	0
5.0	5.0
Off	Off
325	325
400	400

Downloading a Configuration

After you finish customizing the light's settings (or open a Configuration File), click **Send Setting to Device**. This takes the values that are in the *Setting* columns and sends them to the light.

After sending the settings to the light, the information in the *Device* columns changes to match the information in the *Setting* columns, indicating that your changes were successful.

Sending a Configuration to a Light

You can use two methods to create customized settings and send them to a light.

- You can open a Configuration File and send the settings to the light.
- You can individually edit the Setting columns prior to sending the settings to the light.

The following procedure covers both approaches:

1. Remove the light's Bottom Cover and plug the USB cable into the USB port.
2. Connect the other end of the USB cable to an empty USB port on your computer.
3. Open 650DM on your computer. It may take a moment to find and connect to the light.
4. Click **Configuration** on the *Bottom Bar*. The *Configuration* screen appears.
5. Manually change the values in the *Setting* columns to the desired values (then skip to step 7) **-OR-** Open the desired Configuration File by clicking **Get Settings from File...** (and proceed to the following step)
6. Browse to and **Open** the desired Configuration File. The settings from the Configuration File are entered into the *Setting* columns.

7. Click **Send Settings to Device**. The settings from the *Setting* columns are sent to the light, and display in the *Device* columns.

Creating a Configuration File

Different Carmanah lights require different amounts of power to operate at a given configuration (Flash Code, Effective Intensity, etc.). This is due to efficiency differences among LED colours, and optical system differences between Aviation, Obstruction and Marine models.

Because of this, when you create a Configuration File, you should be connected to a light that has the same model number as those that you intend to program with that configuration. This prevents you from specifying a configuration that requires more energy than is available to the light.

To create a Configuration File:

1. Remove the light's Bottom Cover and plug the USB cable into the USB port.
2. Connect the other end of the USB cable to an empty USB port on your computer.
3. Open 650DM on your computer and login as Distributor. It may take a moment to find and connect to the light.
4. Click **Configuration** on the *Bottom Bar*. The *Configuration* page appears.
5. Configure the settings as required to meet the customer's request.
6. In the *File Actions* area on the right side of the page, click **Save Settings to File....** The *Save As* dialog box appears.
7. Navigate to and save the file to an appropriate location. The file is saved in .DCF format. You can now download this Configuration File to as many lights as you would like.

Reading a Configuration File

If you have several Configuration Files stored on your computer, you can open each file to determine the differences between them.

Each Configuration File contains settings for the following parameters: Flash Code, Effective Intensity, Automatic Light Control, D2N Transition, N2D Transition, Switch Mode, User/Distributor Passcodes, Latitude, Longitude, Transmissivity, and the Device Access settings.

To read a Configuration File:

1. Open 650DM on your computer and login as **Distributor**. It may take a moment to find and connect to the light.
2. Click **Configuration** on the Bottom Bar. The *Configuration* page appears.
3. From the *File Actions* area, click **Get Settings from File....** The *Open* dialog box appears.
4. Navigate to the Configuration File you want to view, and click **Open**. The file's configuration settings appear in the *Settings boxes* on the *Configuration Page*.
5. Repeat this procedure with each Configuration File you want to view.

NOTE

Even though the configuration information appears on screen, it is not automatically downloaded to the light. To download the configuration to a light, you must first connect to the light onto which you want to load the settings, then click **Get Settings from File** to open the desired configuration, and then click **Send Settings To Device**.

The order in which you do this is important; if you open the Configuration File and then connect to a light, the light's values overwrite the settings in the

Settings boxes. You must connect to the light, and then open the Configuration File.

Retrieving a Light's Configuration

If you have a light that you know is configured correctly, and you would like to copy this configuration over to other lights, you have to retrieve the light's configuration and save it to your computer (as a DCF file).

To retrieve a device's configuration:

1. Remove the light's Bottom Cover and plug the USB cable into the USB port.
2. Connect the other end of the USB cable to an empty USB port on your computer.
3. Open 650DM on your computer. It may take a moment to find and connect to the light. The light's settings will be copied to the *Settings boxes*.
4. Click **Configuration** on the Bottom Bar. The *Configuration* screen appears.
5. In the *File Actions* area, click **Save Settings to File....** The *Save As* dialog box appears.
6. Navigate to and save the file to an appropriate location. The file is saved in .DCF format. You can now download this Configuration File to as many lights as required.

NOTE

If an OL4 is already connected to the software, and you want to retrieve the light's settings, click **Get Settings From Device**. The light's settings will be copied into the *Settings boxes*.

Saving a Configuration File

If you configure one light exactly how you want it, and would like to copy this configuration over to other lights, you can save the original light's Configuration File, and then copy the file over to the other lights. You can also save a light's Configuration File just so you have a record of how the light is configured.

The Configuration File contains all the values for Flash Code, Effective Intensity, Automatic Light Control, D2N Transition, N2D Transition, Switch Mode, User/Distributor Passcodes, Latitude, Longitude, Transmissivity, and the Device Access settings.

To save a Configuration File:

1. Remove the light's Bottom Cover and plug in the USB cable to the USB port.
2. Connect the other end of the USB cable to an empty USB port on your computer.
3. Open 650DM on your computer. It may take a moment to find and connect to the light. The light's settings will be copied to the *Settings boxes*.
4. Click **Configuration** on the Bottom Bar. The *Configuration* screen appears.
5. In the *File Actions* area, click **Save Settings to File....** The *Save As* dialog box appears.
6. Navigate to and save the file to an appropriate location. The file is saved in .DCF format. You can now download this Configuration File to as many lights as you would like.

NOTE

If an OL4 is already connected to the software, and you want to save the light's settings, click **Get Settings From Device** prior to step 5 above.

Changing Passcodes

Passcode Protected means that a User must enter a Passcode on the OBU before they can edit any settings.

If the Passcode Protected Setting box is clear (and then this setting is sent to the light), the editable settings can be changed without the User having to enter a Passcode on the light.

To remove the Passcode requirement:

1. Open 650DM on your computer and login as **Distributor**. It may take a moment to find and connect to the light.
2. Click **Configuration** on the *Bottom Bar*. The *Configuration* page appears.
3. In the *Set Device Access* area, clear the **Passcode Protected** Setting box.
4. Click **Send Settings To Device**. Any User can now edit the light's configuration using the OBU, without having to enter a Passcode.

If a customer requests a specific Passcode, then as a Distributor you can assign a Passcode to the User.

To assign a specific Passcode to a customer

1. Open 650DM on your computer and login as **Distributor**. 650DM may take a moment to find and connect to the light.
2. Click **Configuration** on the *Bottom Bar*. The *Configuration* page appears.
3. In the *Set Device Passcode* area, type the requested Passcode in the *User Passcode* field.
4. Click **Send Settings To Device**. The updated settings are sent to the light. The next time someone tries to access the light, they will need to know the new Passcode.

Updating the Firmware

Occasionally it may be useful to be able to update new firmware to a 650 light. These files, when necessary, will be supplied by Carmanah Technologies.

NOTE

If you receive specific firmware upgrade installation instructions from Carmanah Technologies with the firmware file, use those instructions instead of the ones below.

To update the firmware on a light:

1. Put the supplied Firmware file (.hex extension) in a suitable location on your hard drive.
2. Remove the light's Bottom Cover and plug the USB cable into the USB port.
3. Connect the other end of the USB cable to an empty USB port on your computer.
4. Open 650DM on your computer. 650DM may take a moment to find and connect to the light.
5. Click **Maintenance** on the *Bottom Bar*. The *Maintenance* page appears.
6. Save the current light's configuration, if you plan to use it after upgrading the firmware. The light's configuration settings may be lost in the firmware upgrade process.
7. In the *Firmware and Flash Code Table* area, click **Update Firmware**. The *Open* dialog box appears
8. Navigate to and select the **.hex** file you saved to your hard drive, and double-click on the file or click **Open**. The following screen appears:



Do not disconnect the light while the firmware is downloading to the light. When the file completes downloading, the following screen appears:

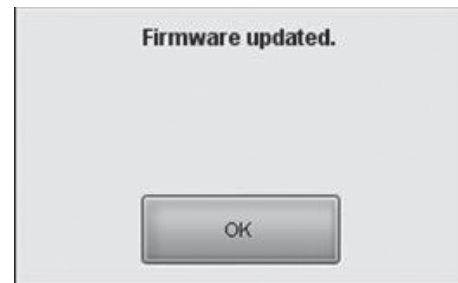

9. Click **OK**. The light firmware has been updated.

Click **Status** in the *Bottom Bar*, and on the *Status* page, look in the *Firmware and Flash Code Table Version* area to confirm the firmware version you are running on your light.

Updating the Flash Code Table

Occasionally it may be useful to load a specific flash code table onto an OL4 light. These files, when necessary, will be supplied by Carmanah Technologies.

To update the Flash Code Table on a light:

1. Put the supplied Flash Code Table file (.csv extension) in a suitable location on your hard drive.
2. Remove the light's Bottom Cover and plug the USB cable into the USB port.
3. Connect the other end of the USB cable to an empty USB port on your computer.
4. Open 650DM on your computer. It may take a moment to find and connect to the light.
5. Click **Maintenance** on the *Bottom Bar*. The *Maintenance* page appears.
6. In the *Firmware and Flash Code Table* area, click **Update Flash Code Table**. The *Open* dialog box appears
7. Navigate to and select the .csv file you saved to your hard drive. The following screen appears:

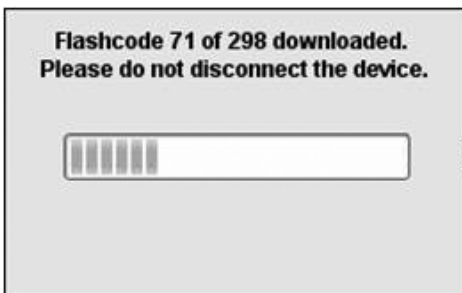

Do not disconnect the light while the Flash Code Table is downloading to the light. When the file completes downloading, the following screen appears:



8. Click **OK**. The Flash Code Table has been updated.

Click **Status** in the *Bottom Bar*, and on the **Status** page, look in the *Firmware* and *Flash Code Table Version* area to confirm the version you are running on your light.

Retrieving a Datalog

If you are experiencing technical difficulties with your light, Carmanah's Helpdesk may ask you to send them a Datalog from the light that they can use for diagnostic purposes.

To obtain a Datalog from a light:

1. Remove the light's Bottom Cover and plug in the USB cable to the USB port.
2. Connect the other end of the USB cable to an empty USB port on your computer.
3. Open 650DM on your computer.
4. Click **Maintenance** on the *Bottom Bar*. The *Maintenance* page appears.
5. In the *Datalogs* area, click **Get Datalog From Device**. The *Browse For Folder* dialog box appears.
6. Navigate to and select the folder into which you want to save the Datalog (for example, your Windows Desktop).
7. Click **OK**. The Datalog file is saved in the specified location. You can now email this Datalog to Carmanah's Helpdesk to diagnose the problem with the light.

Appendix B: Using the Infrared Remote Programmer

The (optional) Infrared Remote Programmer (IR Remote) allows you to access a subset of the OL4 functions. This is useful if the light is bolted down, preventing access to the On-Board User Interface (OBUI) or the USB connector.

NOTE

The IR Remote uses the following codes: User Passcode = 753 Off = 000 Ship Mode = 820 Out of Ship Mode = 821 Batt Check = 810

NOTE

The IR Passcodes (User and Distributor) are the same ones used to login using the OBUI. They can be changed using the Carmanah Device Manager software.

NOTE

If the "Can Change Flash Code" checkbox is cleared in the software, the Flash Code will not be editable when logged in to the OL4 using the User passcode. (The Flash Code can always be edited by logging in with the Distributor Passcode.)

You can perform the following functions with the IR Remote:

- Check the Battery Pack Health
- Change the Flash Code
- Put the OL4 into **Ship Mode**
- Retrieve the OL4 from **Ship Mode**
- Enter **Off Mode**

Entering the Passcode

You must enter a Passcode before you can access any of the IR Remote features.

To enter the Passcode:

1. Point the IR Remote at the side of the OL4.

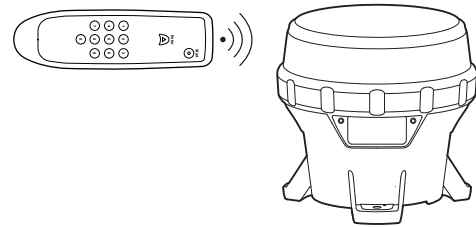

2. Press and hold any button for approximately three seconds. The right-most decimal point on the OBUI illuminates steadily to indicate it received the IR signal and entered IR Edit Mode.
3. Press the **Start** button on the IR Remote. The OBUI displays "**I r Pr**" briefly to indicate that it has received the IR signal.
4. Enter the Passcode using the IR Remote. The default Passcode is **753**. Each time you enter one of the digits for the Passcode, the OBUI flashes "I r X" (where X indicates the button you pressed on the IR Remote. For example, if you press the up button on the IR Remote, the display reads "I r U P"; "I r 0 9" displays when you press the 9 button; etc.).
5. Press the **Enter** button on the IR Remote.
6. After you successfully enter the Passcode, if the main LED was on, it extinguishes and then flashes three times quickly to indicate that the Passcode entry was successful. If the Passcode entry was unsuccessful, the main LED stays lit. This is a security feature to prevent unauthorized persons from interrupting the main LED during operation. Repeat this procedure to enter the Passcode.

NOTE

While you are logged in, the main LED flashes whenever it receives a valid IR transmission.

During the login process, the main LED does NOT flash in response to IR remote button presses

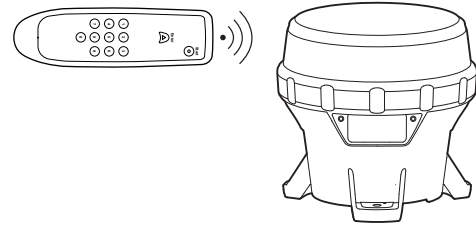

After you successfully login, the OBUI scrolls through a Status Report twice. If the OL4 is not bolted down, you can view the Status Report on the OBUI through the transparent window in the Bottom Cover.

NOTE

IR Timeout After you enter the Passcode, if the OL4 does not detect any IR activity, the IR Interface times out after one minute. If this occurs, press and hold any button on the IR Remote for three seconds, and repeat the Passcode entry process.

NOTE

When using the IR Remote, you must always login using a valid Passcode, even if the Passcode Protected flag is cleared using the software. This is a security feature.

NOTE

If you enter an incorrect Passcode, the OBUI briefly displays the word **Fail**. This may indicate that someone has changed the Passcode using the OL4 Device Manager.

2. Enter the new Flash Code by pressing the **three digits** of the new Flash Code on the IR Remote. The main LED flashes once each time the OL4 receives a valid keypress.
3. Press **Enter** on the IR Remote. If the new Flash Code update was successful, the main LED flashes three times quickly, and then the OL4 runs through the new Flash sequence for one minute (or until another IR transmission is received from the IR Remote). If the new Flash Code update was unsuccessful, the main LED flashes twice slowly.

NOTE

If the main LED responds with two slow flashes after you enter the new Flash Code, then the Flash Code is not valid, or it consumes more than the available energy at the programmed intensity.

Using the OBUI, changing the Flash Code can force the intensity to change, but that does not occur when changing the flash via infrared. This, and the inability of the IR to trigger a status report without first entering a valid Passcode, are two key differences between the OBUI and IR interface.

Either select a different Flash Code, or reduce the effective intensity setting using the OBUI or OL4 Device Manager software.

Changing the Flash Code

The Flash Code you select determines the OL4's flashing pattern. Refer to Appendix F for a complete list of the available Flash Codes.

To change the existing Flash Code:

1. After entering the Passcode, point the IR Remote at the side of the OL4 lens and then press the **Start** button on the IR Remote.

Turning the OL4 Off

To turn the OL4 off using the IR Remote, you must set the Flash Code to 000. To do this:

1. After entering the Passcode, point the IR Remote at the side of the OL4 lens and press the **Start** button on the IR Remote.

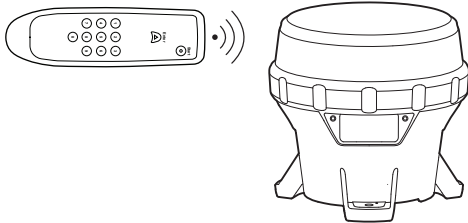

2. Enter the Flash Code "**000**" using the IR Remote. The main LED flashes once each time the OL4 receives a keypress.
3. Press the **Enter** button on the IR Remote. If the Flash Code update was successful, the main LED flashes three times quickly. If the Flash Code update was unsuccessful, the main LED flashes twice slowly. If you were unsuccessful, it means the Flash Code was entered incorrectly. Repeat this process using the Flash Code "**000**".

NOTE

When the OL4 is in **Off** mode, the main LED does not illuminate. However, it continues to charge when exposed to sufficiently intense light.

NOTE

If you set the OL4 to **Off** mode using the OBU, the OL4 will still respond to infrared commands.

4.

Setting the OL4 to Ship Mode

If you are storing an OL4, or have to return it to your distributor for maintenance or repair, it is best to put the OL4 into **Ship Mode** or **Off** mode. When the OL4 exits **Ship Mode** and returns to normal operation, it will remember its Flash Code, intensity and other settings.

To set the OL4 to **Ship Mode**:

1. After entering the Passcode, point the IR Remote at the side of the OL4 lens and then press the **Start** button on the IR Remote.

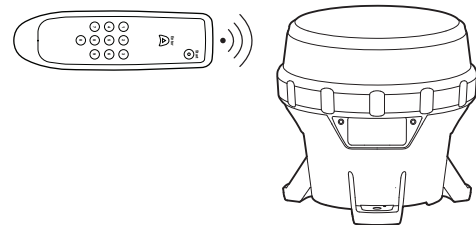

2. Enter **820** using the IR Remote. The main LED flashes once each time the OL4 receives a valid keypress.
3. Press the **Enter** button on the IR Remote. If the **Ship Mode** command was successful, the main LED flashes three times quickly. The OL4 is now in **Ship Mode**. If the command was unsuccessful, the main LED flashes twice slowly. If you were unsuccessful, repeat the process: **Start, 820, Enter**.

After you enter **Ship Mode**, place the OL4 into the box in which it is being stored or shipped, and close the lid. The main LED remains off until the device is removed from the box and senses a day-to-night transition. It then continues to operate in dusk-to-dawn mode. Please follow the storage recommendations outlined on pg. 22.

Restoring the OL4 from Ship Mode

The OL4 automatically exits **Ship Mode** when it detects a day-to-night transition. However, to exit **Ship Mode** manually use the following procedure:

1. After entering the Passcode, point the IR Remote at the side of the OL4 lens and then press the IR Remote **Start** button.

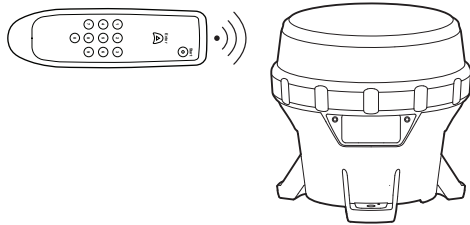

2. Enter **821** using the IR Remote. The main LED flashes once each time the OL4 receives a keypress.
3. Press the **Enter** button on the IR Remote. If the command was successful, the main LED flashes three times quickly. The OL4 is now out of Ship Mode. If the command was unsuccessful, the main LED flashes twice slowly. If you were unsuccessful, repeat this process (Start, **821**, Enter).
4. After you take the OL4 out of Ship Mode, determine the Battery Pack's State of Health using either the OBU or the IR Remote. If the Battery Pack is not in good health, either charge or replace the Battery Pack (see pg. 20, 22).

If you successfully remove the OL4 from **Ship Mode**, the OL4 begins to operate automatically in dusk-to-dawn mode.

NOTE

Check the OL4's Flash Code before deploying it. If the Flash Code is set to **000**, it indicates that the OL4 is in **Off** mode, and the main LED will not turn on even with the arrival of dusk.

Determining the Battery Pack's State of Health

If the OL4 is bolted down, you can use the IR Remote to check the OL4's Battery Pack's state of health.

1. After entering the Passcode, point the IR Remote at the side of the OL4 lens and then press the **Start** button on the IR Remote. The main LED flashes once.

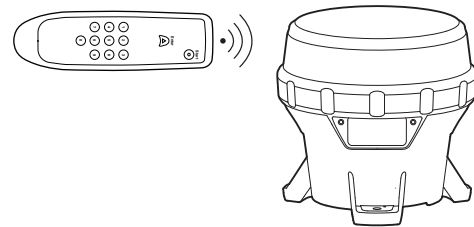

2. Enter **810** using the IR Remote. The main LED flashes once each time the OL4 receives a signal.
3. Press **Start** on the IR Remote. The main LED flashes once, and if the command entry was successful, the main LED will flash three times quickly, and then display the Battery Pack's state of health using a series of flashes from the main LED. Use the following table to determine the Battery Pack's state of health.

Number of Flashes	State of Health
4	Bad
7	Charge
10	Good

If the Battery Pack Health Status Request was unsuccessful, the main LED flashes twice slowly. If you were unsuccessful, repeat this process (**Start**, **810**, **Enter**).

Appendix C: Ordering Codes

The following sections lists the OL4 ordering codes and the accessories available from your Carmanah Distributor:

Ordering Code Format:

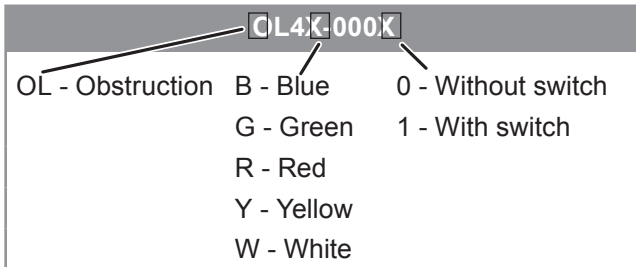

For example, OL4R-0001 is a red, switched light.

OL4 Accessories

OL4 Replacement Battery Pack Part # 57383

A replacement Battery Pack is available for the OL4. The Battery Pack is ready for installation in the OL4 and does not require tools or other parts.



Appendix D: Specifications

Form-Factor

Mounting: 5.9 inch (150 mm), 3-hole
Mounting Orientation: N/A; symmetrical
Over-torque resistant: Yes
Chassis Materials: polycarbonate / polysiloxane alloy
Height: 6.7 inch (169 mm)
Width: 6.9 inch (176 mm)
Weight: 3.5 lb (1.58 kg)
Operating Temp.: -45 to 124 °F (-43 to 51 °C)
Storage Temp.: -45 to 176 °F (-43 to 80 °C)

Optical

Light Source: High-power LED
Intensity: see Carmanah.com specification sheet
Chromaticity: IALA Preferred and Optimum, ICAO, SAE 25050/FAA, AREMA blue
Flash Settings: 256+ Flash Codes
Ambient Light Sensing: 25 - 925 lux, CCG and USCG targets
LED Corrections: Yes - temperature, colour, flash code, efficacy, voltage
Automatic Light Control (ALC): Yes
Visual Colour Indicator: Yes, FAA Eng. Brief 67 compliant.

Energy Capture

Solar Panel Power: High-efficiency cells
Air Gap between Solar Panel and Lens: No
Maximum Power Point Tracking (MPPT): Yes
Float Charge Cut-off: Yes
Battery Charger: Temperature-compensated, constant-voltage
Reverse Polarity Protection: Yes
Solar Panel Bypass Diodes: Yes
Solar Panel Blocking Diode Function: Yes

Energy Storage

Replaceable Battery Pack: Yes (tool-less)
Secured Battery Pack: Yes. Strap material meets ASTM D2000 2BG613-F7-G2
Vented Battery Pack Compartment: Yes
Battery Status Feedback: Good, Charge, Bad (Replace)

User Interface

User Interface: Onboard LED Display; External Switch option; IR option; USB connection to PC
Datalogger: Yes
Self-Test: Yes
Battery Pack State of Health: Yes
External Switch: Optional
Ability to Connect to Computer: Yes - USB
Wireless Control: IR only

Standards and Testing

Class 1 Div 2 Hazardous Environment: Pending
RoHS: Yes
ICAO 2007 Requirements: Yes
FAA Taxiway Requirements: Pending
EMC and EMI: to be approved for EU/CE, USA, CAN, AU, others
Vibration: 10g, 10 - 60 Hz
Shock, Pulse: Tested to MIL-STD-202G, Method 213B, Test Condition G, 50 – 75g
Shock, Handling: 48 inch (122 cm) drop onto solid wood on concrete
Hail: Tested to EN 61215, 1 inch (25 mm) OD up to 50mph (23 m/s)
Wind Loading: 400 mph (180 m/s)
Immersion: IP68, MIL-STD-202G, Method 104A, Test Condition B
Salt Spray: Tested to MIL_STD-810G, ASTM B117-73(1979)
ESD: Tested to EN 61000-6-2:2001, +/-8 to +/-25 kV Discharge
Chemical Resistance: Tested to MIL-STD-810G, Method 504, Procedure II

Standards and Testing (continued)

Vandalism: Tested to withstand hits from a 27 inch (69 cm) bat

Pressure Washer: Tested to withstand up to 2900 psi (20 MPa)

Mounting Over-torque: Tested to withstand up to 65 ft-lb (88 N-m)

Humidity/Damp Heat: Tested to MIL-STD-810G, Method 507.5

UV Exposure: Tested to MIL-STD-810G, Method 505.5, Procedure II, 1120 W/m², 44°C

RF/EMI Resilience: Tested to EN 60945:2002, EN 61000-4-3:1995, 100MHz -1GHz, 10V/m and 1GHz -12GHz, 200V/m

Battery Life: Tested equivalent to IEC 61427

Patents

US 6,573,659 and other US, Canadian, EU patents pending

Mounting

Mounting bolt size: 0.25 inch (6mm or 7mm)

Mounting foot thickness: 0.5 inch (12.7mm)

Mounting bolt torque (minimum): 4 lbf·ft (5.4 N·m)

Mount post diameter (minimum): 7 inch (177mm)

Bolt circle diameter: 5.91 inch (150mm)

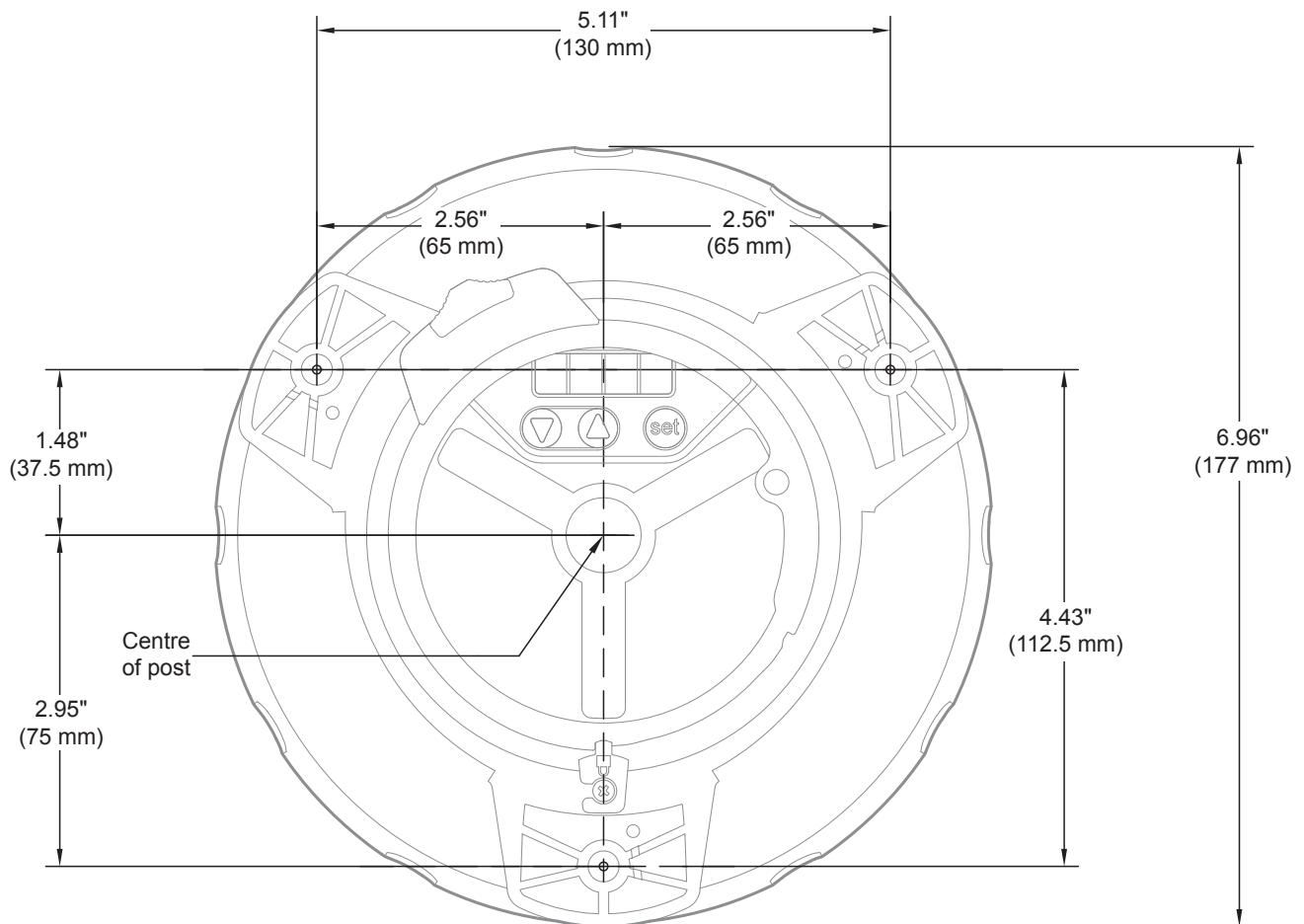

Photometric Plots

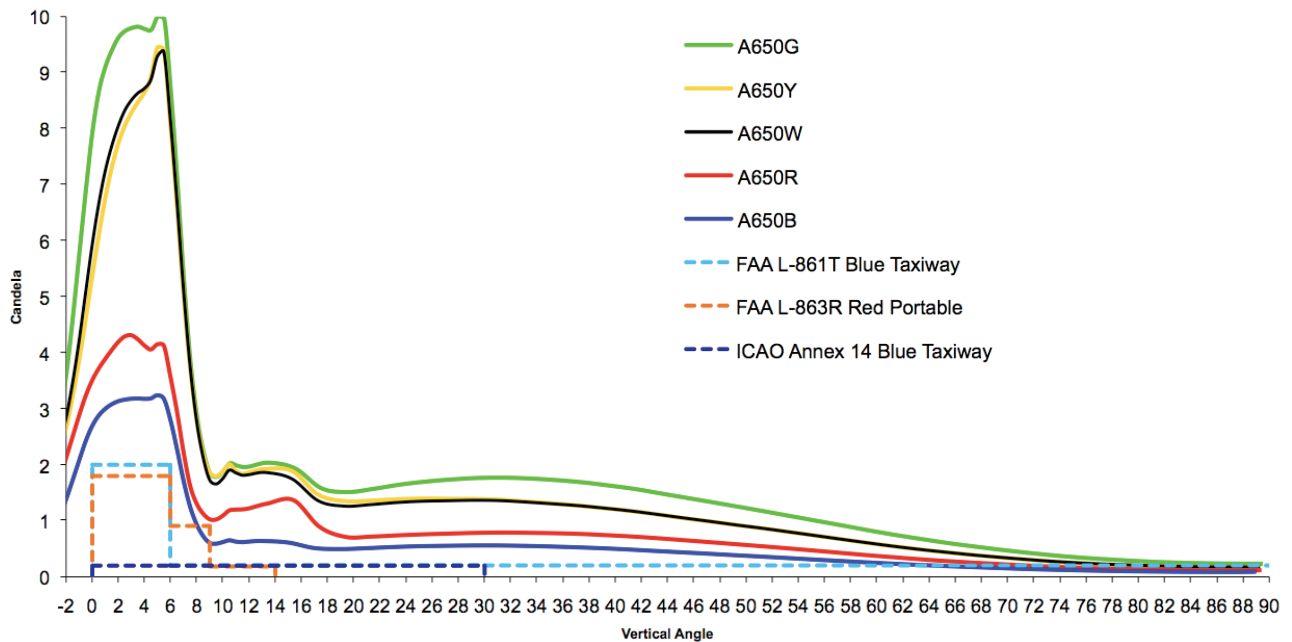
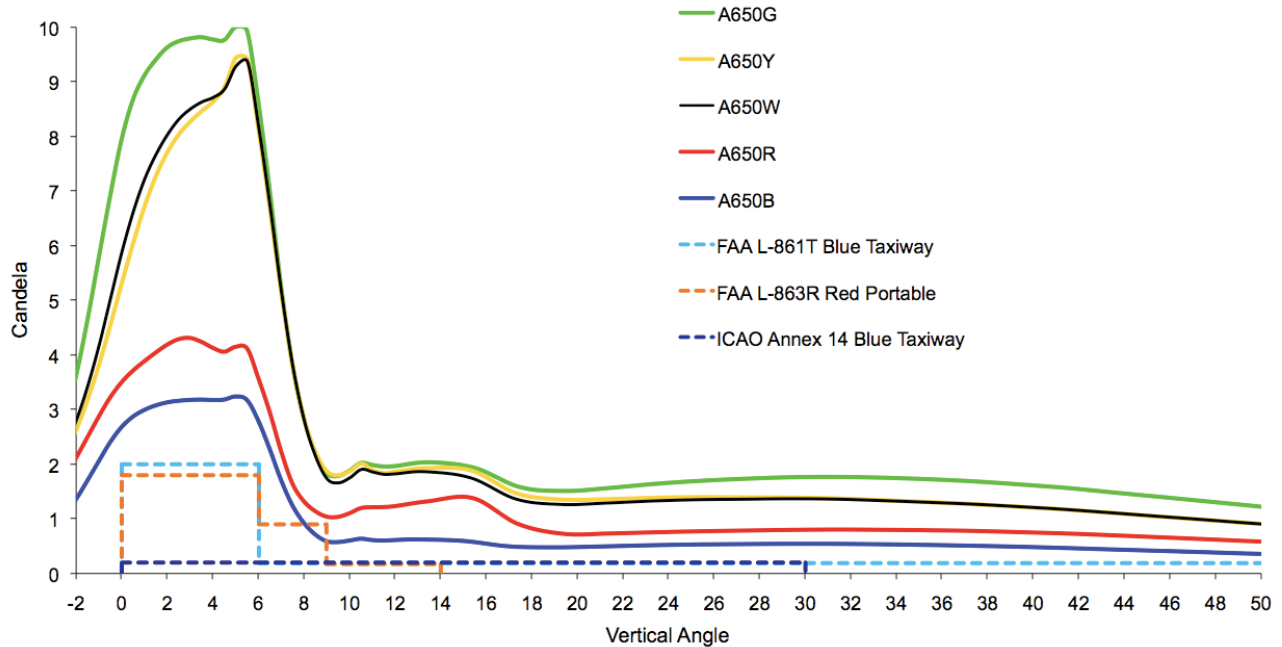
NOTE

Intensity dependant on location.
Based on equatorial location
of 12-hour night duration and
steady-on (001) flash code.

Appendix E: Flash Codes

Flash Code	Flash Character	F11	EC1	F12	EC2	F13	EC3	F14	EC4	F15	EC5	F16	EC6	F17	EC7	F18	EC8	F19	EC9
1	F	60	0																
2	FI(2) 10s	0.5	1	0.5	8														
3	FI(2) 10s	0.5	1.5	0.5	7.5														
4	FI(2) 10s	0.8	1.2	0.8	7.2														
5	FI(2) 10s	1	1	1	7														
6	FI(2) 10s	1	1.5	1	6.5														
7	FI(2) 12s	0.5	1	0.5	10														
8	FI(2) 12s	1.5	2	1.5	7														
9	FI(2) 15s	1	2	1	11														
10	FI(2) 5s	0.5	1	0.5	3														
11	FI(2) 5s	1	1	1	2														
12	FI(2) 6s	0.5	1	0.5	4														
13	FI(2) 6s	0.8	1.2	0.8	3.2														
14	FI(2) 6s	1	1	1	3														
15	FI(2) 7s	1	1	1	4														
16	FI(2) 8s	0.5	1	0.5	6														
17	FI(2) 8s	1	1	1	5														
18	FI(2+1) 10s	0.5	0.7	0.5	2.1	0.5	5.7												
19	FI(2+1) 12s	0.8	1.2	0.8	2.4	0.8	6												
20	FI(2+1) 12s	1	1	1	4	1	4												
21	FI(2+1) 15s	1	2	1	5	1	5												
22	FI(2+1) 6s	0.3	0.4	0.3	1.2	0.3	3.5												
23	FI(3) 12S	0.5	2	0.5	2	0.5	6.5												
24	FI(3) 10s	0.5	1.5	0.5	1.5	0.5	5.5												
25	FI(3) 10s	1	1	1	1	1	5												
26	FI(3) 12s	0.8	1.2	0.8	1.2	0.8	7.2												
27	FI(3) 15s	0.3	1.7	0.3	1.7	0.3	10.7												
28	FI(3) 15s	0.5	1.5	0.5	1.5	0.5	10.5												
29	FI(3) 20s	0.5	3	0.5	3	0.5	12.5												

Flash Code	Flash Character	F11	EC1	F12	EC2	F13	EC3	F14	EC4	F15	EC5	F16	EC6	F17	EC7	F18	EC8	F19	EC9
30	FI(3) 9s	0.8	1.2	0.8	1.2	0.8	4.2												
31	FI(4) 10s	0.5	1	0.5	1	0.5	1	0.5	5										
32	FI(4) 10s	0.8	1.2	0.8	1.2	0.8	1.2	0.8	3.2										
33	FI(4) 12s	0.8	1.2	0.8	1.2	0.8	1.2	0.8	5.2										
34	FI(4) 15s	0.5	1.5	0.5	1.5	0.5	1.5	0.5	8.5										
35	FI(4) 15s	1	1	1	1	1	1	1	8										
36	FI(4) 20s	0.5	1.5	0.5	1.5	0.5	1.5	0.5	13.5										
37	FI(5) 20s	0.8	1.2	0.8	1.2	0.8	1.2	0.8	1.2	0.8	11.2								
38	FI(5) 20s	1	1	1	1	1	1	1	1	1	11								
39	FI(6) 15s	0.5	1	0.5	1	0.5	1	0.5	1	0.5	1	0.5	7						
40	FL-*	5	1	1	1														
41	FL-**	5	1	1	1	1	1												
42	FI 1.5s	0.3	1.2																
43	FI 1.5s	0.5	1																
44	FI 10s	0.5	9.5																
45	FI 10s	1	9																
46	FI 10s	1.5	8.5																
47	FI 12s	1.2	10.8																
48	FI 15s	1	14																
49	FI 2.5s	0.3	2.2																
50	FI 2.5s	0.5	2																
51	FI 2.8s	0.3	2.5																
52	FI 2s	0.2	1.8																
53	FI 2s	0.3	1.7																
54	FI 2s	0.4	1.6																
55	FI 2s	0.5	1.5																
56	FI 2s	0.7	1.3																
57	FI 2s	0.8	1.2																
58	FI 3s	0.3	2.7																
59	FI 3s	0.5	2.5																

Flash Code	Flash Character	F11	EC1	F12	EC2	F13	EC3	F14	EC4	F15	EC5	F16	EC6	F17	EC7	F18	EC8	F19	EC9
60	FI 3s	0.7	2.3																
61	FI 3s	1	2																
62	FI 4.3s	1.3	3																
63	FI 4.4s	0.4	4																
64	FI 4s	0.5	3.5																
65	FI 4s	0.8	3.2																
66	FI 4s	1	3																
67	FI 4s	1.5	2.5																
68	FI 5s	0.3	4.7																
69	FI 5s	0.5	4.5																
70	FI 5s	1	4																
71	FI 5s	1.5	4.5																
72	FI 6s	0.5	5.5																
73	FI 6s	0.6	5.4																
74	FI 6s	1	5																
75	FI 6s	1.5	3.5																
76	FI 7.5s	0.8	6.7																
77	ISO 10S	5	5																
78	ISO 2S	1	1																
79	ISO 4S	2	2																
80	ISO 5S	2.5	2.5																
81	ISO 6S	3	3																
82	ISO 8S	4	4																
83	ISO 3S	1.5	1.5																
84	LFL 10S	2	8																
85	LFL 10S	3	7																
86	LFL 10S	4	6																
87	LFL 12S	2	10																
88	LFL 15S	4	11																
89	LFL 5S	2	3																

Flash Code	Flash Character	F11	EC1	F12	EC2	F13	EC3	F14	EC4	F15	EC5	F16	EC6	F17	EC7	F18	EC8	F19	EC9
90	LFL 6S	2	4																
91	LFL 8S	2	6																
92	LFL 8S	3	5																
93	MO(A) 10S	0.5	0.5	1.5	7.5														
94	MO(A) 15s	0.5	1.5	2	11														
95	MO(A) 6s	0.3	0.6	1	4.1														
96	MO(A) 8s	0.8	1.2	2.4	3.6														
97	MO(B) 15S	1.5	0.5	0.5	0.5	0.5	0.5	0.5	10.5										
98	MO(U) 10S	0.3	0.7	0.3	0.7	0.9	7.1												
99	MO(U) 10S	0.4	0.6	0.4	0.6	1.2	6.8												
100	MO(U) 10S	0.5	0.5	0.5	0.5	1.5	6.5												
101	MO(U) 15S	0.5	0.5	0.5	0.5	1.5	11.5												
102	MO(U) 15S	0.6	0.3	0.6	0.3	1.4	11.8												
103	MO(U) 15S	0.7	0.5	0.7	0.5	1.9	10.7												
104	MO(U) 15S	0.7	0.7	0.7	0.7	2.1	10.1												
105	MO(U) 15S	0.75	0.45	0.75	0.45	2	10.6												
106	MO(U) 15S	1.15	0.73	1.15	0.73	3.03	8.21												
107	MO(U) 15S	1.3	0.7	1.3	0.7	3.3	7.7												
108	MO(U) 15S****	0.75	0.15	0.75	0.15	1.65	11.55												
109	MO(U) 15S*	0.45	0.45	0.45	0.45	1.35	11.85												
110	MO(U) 15S**	0.55	0.35	0.55	0.35	1.45	11.75												
111	MO(U) 15S***	0.6	0.3	0.6	0.3	1.5	11.7												
112	MO(U) 10S	0.2	0.8	0.2	0.8	0.6	7.4												
113	OC 10S	7	3																
114	OC 10S	7.5	2.5																
115	OC 15S	10	5																
116	OC 3S	2	1																
117	OC 3S	2.5	0.5																

Flash Code	Flash Character	F11	EC1	F12	EC2	F13	EC3	F14	EC4	F15	EC5	F16	EC6	F17	EC7	F18	EC8	F19	EC9
118	OC 4S	3	1																
119	OC 5S	3	2																
120	OC 5S	4	1																
121	OC 5S	4.5	0.5																
122	OC 6S	4	2																
123	OC 6S	4.5	1.5																
124	OC 6S	5	1																
125	Q 1.2S	0.3	0.9																
126	Q 1.2S	0.5	0.7																
127	Q 1.2S	0.6	0.6																
128	Q 1S	0.2	0.8																
129	Q 1S	0.3	0.7																
130	Q 1S	0.4	0.6																
131	Q 1S	0.5	0.5																
132	Q 1S	0.8	0.2																
133	Q(2) 10S	0.5	1.5	0.5	7.5														
134	Q(2) 10S	0.6	0.4	0.6	8.4														
135	Q(2) 5S	0.3	0.7	0.3	3.7														
136	Q(2) 6S	0.3	0.7	0.3	4.7														
137	Q(2) 6S	0.35	0.7	0.35	4.6														
138	Q(3) 10S	0.3	0.7	0.3	0.7	0.3	7.7												
139	Q(3) 10S	0.35	0.65	0.35	0.65	0.35	7.65												
140	Q(3) 10S	0.6	0.6	0.6	0.6	0.6	7												
141	Q(4) 10S	0.3	0.7	0.3	0.7	0.3	0.7	0.3	6.7										
142	Q(4) 12S	0.3	0.7	0.3	0.7	0.3	0.7	0.3	8.7										
143	Q(4) 15S	0.35	0.7	0.35	0.7	0.35	0.7	0.35	11.5										
144	Q(4) 20S	0.5	0.5	0.5	0.5	0.5	0.5	0.5	16.5										
145	Q(4) 6S	0.4	0.6	0.4	0.6	0.4	0.6	0.4	2.6										
146	Q(5) 10S	0.3	0.7	0.3	0.7	0.3	0.7	0.3	0.7	0.3	5.7								
147	Q(5) 20S	0.3	0.7	0.3	0.7	0.3	0.7	0.3	0.7	0.3	15.7								

Flash Code	Flash Character	F11	EC1	F12	EC2	F13	EC3	F14	EC4	F15	EC5	F16	EC6	F17	EC7	F18	EC8	F19	EC9
148	Q(5) 20S	0.5	0.5	0.5	0.5	0.5	0.5	0.5	0.5	0.5	15.5								
149	Q(5) 7S	0.3	0.7	0.3	0.7	0.3	0.7	0.3	0.7	0.3	2.7								
150	Q(6) 10S	0.3	0.7	0.3	0.7	0.3	0.7	0.3	0.7	0.3	0.7	0.3	4.7						
151	Q(6)+LFL 15S	0.3	0.7	0.3	0.7	0.3	0.7	0.3	0.7	0.3	0.7	0.3	0.7	2	7				
152	Q(6)+LFL 15S	0.35	0.65	0.35	0.65	0.35	0.65	0.35	0.65	0.35	0.65	0.35	0.65	1.05	7.95				
153	Q(6)+LFL 15S	0.6	0.6	0.6	0.6	0.6	0.6	0.6	0.6	0.6	0.6	0.6	0.6	2	5.8				
154	Q(9) 15S	0.3	0.7	0.3	0.7	0.3	0.7	0.3	0.7	0.3	0.7	0.3	0.7	0.3	0.7	0.3	0.7	0.3	6.7
155	Q(9) 15S	0.35	0.65	0.35	0.65	0.35	0.65	0.35	0.65	0.35	0.65	0.35	0.65	0.35	0.65	0.35	0.65	0.35	6.65
156	Q(9) 15S	0.6	0.6	0.6	0.6	0.6	0.6	0.6	0.6	0.6	0.6	0.6	0.6	0.6	0.6	0.6	0.6	0.6	4.8
157	VQ 0.5S	0.15	0.35																
158	VQ 0.5S	0.2	0.3																
159	VQ 0.6S	0.2	0.4																
160	VQ 0.6S	0.3	0.3																
161	VQ(3) 5S	0.15	0.35	0.15	0.35	0.15	3.85												
162	VQ(3) 5S	0.2	0.3	0.2	0.3	0.2	3.8												
163	VQ(3) 5S	0.3	0.3	0.3	0.3	0.3	3.5												
164	VQ(6)+LFL 10S	0.2	0.3	0.2	0.3	0.2	0.3	0.2	0.3	0.2	0.3	0.2	0.3	2	5				
165	VQ(6)+LFL 10S	0.3	0.3	0.3	0.3	0.3	0.3	0.3	0.3	0.3	0.3	0.3	0.3	2	4.4				
166	VQ(9) 10S	0.15	0.35	0.15	0.35	0.15	0.35	0.15	0.35	0.15	0.35	0.15	0.35	0.15	0.35	0.15	0.35	0.15	5.85
167	VQ(9) 10S	0.2	0.3	0.2	0.3	0.2	0.3	0.2	0.3	0.2	0.3	0.2	0.3	0.2	0.3	0.2	0.3	0.2	5.8
168	VQ(9) 10S	0.3	0.3	0.3	0.3	0.3	0.3	0.3	0.3	0.3	0.3	0.3	0.3	0.3	0.3	0.3	0.3	0.3	4.9
169	Q(2) 7S	0.5	1	0.5	5														
170	FI(2) 5s	0.3	0.4	0.3	4														
171	FI(2) 10s	0.5	0.7	0.5	8.3														
172	FI(5) 20s	0.5	1	0.5	1	0.5	1	0.5	1	0.5	13.5								
173	FI(2) 10s	1	2	1	6														
174	FI 4s	0.4	3.6																

Flash Code	Flash Character	F11	EC1	F12	EC2	F13	EC3	F14	EC4	F15	EC5	F16	EC6	F17	EC7	F18	EC8	F19	EC9
175	FI(2) 5s	0.4	0.6	0.4	3.6														
176	Mo(A) 8s	0.4	0.6	2	5														
177	FI 2.5s	1	1.5																
178	FI(3+1) 20 s	0.5	1.5	0.5	1.5	0.5	4.5	0.5	10.5										
179	FI(3+1) 20 s	0.6	1.4	0.6	1.4	0.6	4.4	0.6	10.4										
180	FI(3+1) 20 s	0.65	1.35	0.65	1.35	0.65	4.35	0.65	10.35										
181	FI(3+1) 20 s	0.7	1.3	0.7	1.3	0.7	4.3	0.7	10.3										
182	FI(3+1) 20 s	0.8	1.2	0.8	1.2	0.8	4.2	0.8	10.2										
183	FI(2) 7s	0.5	1.5	0.5	4.5														
184	FI(3) 9s	0.5	1.5	0.5	1.5	0.5	4.5												
185	LFL 11s	2	9																
186	FI(6+1) 15s	0.5	0.5	0.5	0.5	0.5	0.5	0.5	0.5	0.5	0.5	0.5	0.5	2	7				
187	Mo (0) 12s	1.5	0.5	1.5	0.5	1.5	6.5												
188	Mo (0) 15s	1.5	0.5	1.5	0.5	1.5	9.5												
189	Q 1S	0.25	0.75																
190	Q (3) 4.6s	0.3	0.7	0.3	2	0.3	1												
191	FI 7.5s	0.5	7																
192	FI (4) 11s	0.5	1.5	0.5	1.5	0.5	1.5	0.5	4.5										
193	FL (3) 21s	0.5	1.5	0.5	4.5	0.5	13.5												
194	FL (3) 6s	0.5	0.5	0.5	0.5	0.5	3.5												
195	FL(3)10s	0.5	0.5	0.5	0.5	0.5	7.5												
196	FL(9)15s	0.5	0.5	0.5	0.5	0.5	0.5	0.5	0.5	0.5	0.5	0.5	0.5	0.5	0.5	0.5	0.5	0.5	6.5
197	OC(2)6s	3	1	1	1														
198	OC(3)8s	3	1	1	1	1	1												
199	OC(4)10s	3	1	1	1	1	1	1	1										
200	FL(2)6s	0.5	1.5	0.5	3.5														
201	FL(1)8s	0.5	7.5																
202	FL(3)15s	0.3	1.7	0.3	1.7	0.3	10.7												
203	FL(2)5s	0.2	0.8	0.2	3.8														
204	FL(2)4s	0.5	1	0.5	2														

Flash Code	Flash Character	F11	EC1	F12	EC2	F13	EC3	F14	EC4	F15	EC5	F16	EC6	F17	EC7	F18	EC8	F19	EC9
205	FL(2)4.5s	0.3	1	0.3	2.9														
206	FL(3)10s	0.5	1.5	0.5	1.5	0.5	5.5												
207	FL(3)15s	0.5	1.5	0.5	1.5	0.5	10.5												
208	Mo(B)16s	1.5	0.5	0.5	0.5	1.5	0.5	0.5	10.5										
209	Q 1s	0.15	0.85																
210	FI(2+1) 10s	0.6	0.6	0.6	1.8	0.6	5.8												
211	MO(U) 15S	0.4	0.5	0.4	0.5	1.2	12												
212	Q 1.2S	0.2	1																
213	Q(3) 10S	0.2	1	0.2	1	0.2	7.4												
214	Q(6)+LFL 15S	0.6	0.6	0.6	0.6	0.6	0.6	0.6	0.6	0.6	0.6	0.6	0.6	3	4.8				
215	VQ(3) 5S	0.2	0.4	0.2	0.4	0.2	3.6												
216	VQ(6)+LFL 10S	0.3	0.3	0.3	0.3	0.3	0.3	0.3	0.3	0.3	0.3	0.3	0.3	3	3.4				
217	VQ(9) 10S	0.2	0.4	0.2	0.4	0.2	0.4	0.2	0.4	0.2	0.4	0.2	0.4	0.2	0.4	0.2	0.4	0.2	5
218	OC (3) 12S	4.5	1.5	1.5	1.5	1.5	1.5												
219	OC(4) 12S	5	1	1	1	1	1	1	1										
220	FL(3) 12S	1	1.5	1	1.5	1	6												
221	FL(4) 15S	1	1.5	1	1.5	1	1.5	1	6.5										
222	FL(5) 20S	1	1.5	1	1.5	1	1.5	1	1.5	1	9								
223	MO(A)	1	1	3	7														
224	FL(5) 20S SADO	0.5	1.5	0.5	1.5	0.5	1.5	0.5	1.5	0.5	11.5								
225	FL(4) 15S	0.5	2	0.5	2	0.5	2	0.5	7										
226	FL(5) 20S	0.5	2	0.5	2	0.5	2	0.5	2	0.5	9.5								
227	Q(6)+LFL 15S	0.2	1	0.2	1	0.2	1	0.2	1	0.2	1	0.2	1	3	4.8				
228	Q(9) 15S	0.2	1	0.2	1	0.2	1	0.2	1	0.2	1	0.2	1	0.2	1	0.2	1	0.2	5.2
229	VQ(6)+LFL 10S	0.2	0.4	0.2	0.4	0.2	0.4	0.2	0.4	0.2	0.4	0.2	0.4	3	3.4				
230	CST1	3.273	1.091	1.091	1.091	3.273	1.091	1.091	30										
231	CST2	6	15																

Flash Code	Flash Character	F11	EC1	F12	EC2	F13	EC3	F14	EC4	F15	EC5	F16	EC6	F17	EC7	F18	EC8	F19	EC9
232	LFL 24s	9	15																
233	CST4	3	10																
234	CST5	0.5	1	0.5	1	0.5	4.5												
235	CST6	0.4	0.7	0.4	0.7	0.4	0.7	0.4	0.7	0.4	20.2								
236	CST7	1.5	0.5																
237	CST8	0.5	2.5	0.5	2.5	0.5	2.5	0.5	10.5										
238	CST9	0.6	0.3	0.6	0.3	1.5	56.7												
239	CST10	0.5	1.5	0.5	2.5														
240	CST11	0.3	0.7	0.3	2.7														
241	CST12	6	6																
242	CST13	2	1	5	1														
243	CST14	0.4	0.6	0.4	0.6	0.4	2.6												
244	CST15	0.8	1	0.8	1	0.8	1	0.8	1	0.8	2								
245	CST16	0.8	1	0.8	1	0.8	1	0.8	3.8										
246	CST17	0.5	0.5	0.5	0.5	0.5	5.5												
247	CST18	0.5	2.5	0.5	2.5	0.5	2.5	0.5	10.5										
248	CST19	0.8	5.2																
249	CST20	0.8	6.2																
250	CST21	0.5	2	0.5	2	0.5	2	0.5	8										
251	FI 3.5s	0.7	2.8																
252	FI 3.6s	0.7	2.9																
253	FI 5.5s	0.7	4.8																
254	FI(3) 15s	0.5	1.5	0.5	3	0.5	9												
255	GpD(5) 14s	0.5	1.5	0.5	1.5	0.5	1.5	0.5	1.5	0.5	5.5								
256	GpD(5) 15s	0.5	1.5	0.5	1.5	0.5	1.5	0.5	1.5	0.5	6.5								
257	ISO 2.5S	1.25	1.25																
258	FI(3) 10s	0.5	1.5	0.5	0.5	1.5	5.5												
259-297	SYS: future use	0	0																
298	ENDCODE																		

Appendix F: Warranty and Customer Service Information

Warranty

This product is covered by the Carmanah warranty. Please contact Customer Service or an Authorized Carmanah Distributor for more information.

Customer Service

Before contacting Carmanah's Customer Service department, please have the serial number of your OL4 available, a brief description of the problem, as well as all details of installation, storage, and recharging efforts.

To contact Carmanah's Customer Service Department:

Mail: Carmanah Technologies Corporation
250 Bay Street
Victoria, BC Canada V9A 3K5

Phone: 1.250.380.0052
877.722.8877 (Toll Free in U.S. and Canada)

Fax: 1.250.380.0062

Email: customerservice@carmanah.com

Website: carmanah.com

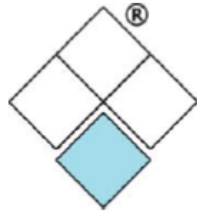

SARTELCO® SISTEMI SRL

Via Torri Bianche, 1
20871 Vimercate (MB)

Tel. +39- 039- 62905.1 Fax. +39- 039- 62905.99
e-mail sistemi@sartelco.it Web www.sartelco.it



© 2014 Carmanah Technologies
Corporation carmanah.com

Technical Support:

Email: customerservice@carmanah.com

Worldwide: 1.250.380.0052

we put solar to work™